

Pumps

P54W, P58W, P59W & P59MT

Triplex Ceramic
Plunger Pump
Operating Instructions/
Repair and Service
Manual



*P59 Shown
(P54 & P58 pump have single sided crankshafts)*

Contents:

Installation Instructions:	page 2
Pump Specifications:	pages 3-5
Exploded View:	page 6
Parts List:	page 7
Kits/ Torque Specs.:	page 8
Pump Mounting Selection Guide:	page 8
Trouble Shooting:	page 9
Recommended Spare Parts List:	page 9
Repair Instructions:	pages 10-14
Dimensions:	page 15
Warranty Information:	back page

INSTALLATION INSTRUCTIONS

Installation of the Giant Industries, Inc., pump is not a complicated procedure, but there are some basic steps common to all pumps. The following information is to be considered as a general outline for installation. If you have unique requirements, please contact Giant Industries, Inc. or your local distributor for assistance.

1. The pump should be installed flat on a base to a maximum of a 15 degree angle of inclination to ensure optimum lubrication.
2. The inlet to the pump should be sized for the flow rate of the pump with no unnecessary restrictions that can cause cavitation. Teflon tape should be used to seal all joints. If pumps are to be operated at temperatures in excess of 160° F, it is important to insure a positive head to the pump to prevent cavitation.
3. The discharge plumbing from the pump should be properly sized to the flow rate to prevent line pressure loss to the work area. It is essential to provide a safety bypass valve between the pump and the work area to protect the pump from pressure spikes in the event of a blockage or the use of a shut-off gun.

4. Use of a dampener is necessary to minimize pulsation at drive elements, plumbing, connections, and other system areas. The use of a dampener with Giant Industries, Inc. pumps is optional, although recommended by Giant Industries, Inc. to further reduce system pulsation. Dampeners can also reduce the severity of pressure spikes that occur in systems using a shut-off gun. A dampener must be positioned downstream from the unloader.

5. Crankshaft rotation on Giant Industries, Inc. pumps should be made in the direction designated by the arrows on the pump crankcase. Reverse rotation may be safely achieved by following a few guidelines available upon request from Giant Industries, Inc. Required horsepower for system operation can be obtained from the charts on pages 3-5.

6. Before beginning operation of your pumping system, remember: Check that the crankcase and seal areas have been properly lubricated per recommended schedules. Do not run the pump dry for extended periods of time. Cavitation will result in severe damage. Always remember to check that all plumbing valves are open and that pumped media can flow freely to the inlet of the pump.

Finally, remember that high pressure operation in a pump system has many advantages. But, if it is used carelessly and without regard to its potential hazard, it can cause serious injury.

IMPORTANT OPERATING CONDITIONS

Failure to comply with any of these conditions invalidates the warranty.

1. Prior to initial operation, add oil to the crankcase so that oil level is between the two lines on the oil dipstick. **DO NOT OVERFILL.**

Use Giant synthetic oil.

Crankcase oil should be changed after the first 50 hours of operation, then at regular intervals of 500 hours or less depending on operating conditions.

2. Pump operation must not exceed rated

pressure, volume, or RPM. A pressure relief device must be installed in the discharge of the system.

3. Acids, alkalines, or abrasive fluids cannot be pumped unless approval in writing is obtained before operation from Giant Industries, Inc.

4. Run the pump dry approximately 10 seconds to drain the water before exposure to freezing temperatures.

Specifications Model P54W

Ratings (Continuous)	4.0 GPM @ 4000 PSI @ 1450 RPM
Ratings (Intermittent)	4.8 GPM @ 3300 PSI @ 1750 RPM
Inlet Pressure	Up to 140 PSI
Plunger Diameter	16mm
Stroke	18.1mm
Crankcase Oil Capacity	14 fl.oz.
Temperature of Pumped Fluids	Up to 160° F
Inlet Ports	(2) 3/8" BSP & (1) 1/2" BSP
Discharge Ports	(2) 3/8" BSP
Crankshaft Mounting	Either Side
Shaft Rotation	Top of Pulley Towards Fluid End
Weight	19 lbs.
Crankshaft Diameter	24mm
Volumetric Efficiency @ 1450	0.96
Mechanical Efficiency @ 1450	0.84

Consult the factory for special requirements that must be met if the pump is to operate beyond one or more of the limits specified above.

PULLEY INFORMATION

Pulley selection and pump speed are based on a 1725 RPM motor and "B" section belts. When selecting desired GPM, allow for a ±5% tolerance on pumps output due to variations in pulleys, belts and motors among manufacturers.

1. Select GPM required, then select appropriate motor and pump pulley from the same line.
2. The desired pressure is achieved by selecting the correct nozzle size that corresponds with the pump GPM.

HORSEPOWER INFORMATION

Horsepower ratings shown are the power requirements for the pump. Gas engine power outputs must be approximately twice the pump power requirements shown above.

We recommend that a 1.1 service factor be specified when selecting an electric motor as the power source. To compute specific pump horsepower requirements, use the following formula:

$$HP = (GPM \times PSI) / 1460$$

P54W PULLEY SELECTION & HORSEPOWER REQUIREMENTS							
PUMP PULLEY	MOTOR PULLEY	RPM	GPM	2000 PSI	3000 PSI	3300 PSI	4000 PSI*
7.75"	4.25"	910	2.5	3.4	5.1	5.7	6.8
7.75"	4.75"	1025	2.8	3.8	5.8	6.3	7.7
7.75"	5.45"	1190	3.3	4.5	6.8	7.5	9.0
7.75"	5.95"	1305	3.6	4.9	7.4	8.1	9.9
7.75"	6.50"	1450	4.0	5.5	8.2	9.0	
7.75"	7.75"	1750*	4.8	6.6	9.9	10.8	

*Intermittent Duty Only

Specifications Model P58W

Ratings (Continuous)	5.0 GPM @ 3500 PSI @ 1450 RPM
Ratings (Intermittent)	6.0 GPM @ 3000 PSI @ 1750 RPM
Inlet Pressure	Up to 140 PSI
Plunger Diameter	18mm
Stroke	18.1mm
Crankcase Oil Capacity	14 fl.oz.
Temperature of Pumped Fluids	Up to 160°F
Inlet Ports	(2) 3/8" BSP & (1) 1/2" BSP
Discharge Ports	(2) 3/8" BSP
Crankshaft Mounting	Either Side
Shaft Rotation	Top of Pulley Towards Fluid End
Weight	19 lbs.
Crankshaft Diameter	24mm
Volumetric Efficiency @ 1450	0.96
Mechanical Efficiency @ 1450	0.84

Consult the factory for special requirements that must be met if the pump is to operate beyond one or more of the limits specified above.

PULLEY INFORMATION

Pulley selection and pump speed are based on a 1725 RPM motor and "B" section belts. When selecting desired GPM, allow for a ±5% tolerance on pumps output due to variations in pulleys, belts and motors among manufacturers.

1. Select GPM required, then select appropriate motor and pump pulley from the same line.
2. The desired pressure is achieved by selecting the correct nozzle size that corresponds with the pump GPM.

HORSEPOWER INFORMATION

Horsepower ratings shown are the power requirements for the pump. Gas engine power outputs must be approximately twice the pump power requirements shown above.

We recommend that a 1.1 service factor be specified when selecting an electric motor as the power source. To compute specific pump horsepower requirements, use the following formula:

$$HP = (GPM \times PSI) / 1460$$

P58W PULLEY SELECTION & HORSEPOWER REQUIREMENTS							
PUMP PULLEY	MOTOR PULLEY	RPM	GPM	2000 PSI	2500 PSI	3000 PSI	3500 PSI
7.75"	4.25"	910	3.1	4.2	5.3	6.4	7.4
7.75"	4.75"	1025	3.5	4.8	6.0	7.2	8.4
7.75"	5.45"	1190	4.1	5.6	7.0	8.4	9.8
7.75"	5.95"	1305	4.5	6.2	7.7	9.2	10.8
7.75"	6.50"	1450	5.0	6.8	8.6	10.3	12.0
7.75"	7.35"	1600	5.5	7.5	9.4	11.3	
7.75"	7.75"	1750*	6.0	8.2	10.3	12.3	

*Intermittent Duty Only

Specifications

Model P59 and P59MT-0020

Ratings (Continuous)	7.5 GPM @ 1900 PSI @ 1450 RPM
Ratings (Intermittent)	9.0 GPM @ 1000 PSI @ 1750 RPM
Inlet Pressure	Up to 140 PSI
Plunger Diameter	22mm
Stroke	18.1mm
Crankcase Oil Capacity	14 fl.oz.
Temperature of Pumped Fluids	Up to 160° F
Inlet Ports	(2) 3/8" BSP & (1) 1/2" BSP
Discharge Ports	(2) 3/8" BSP
Crankshaft Mounting	Either Side
Shaft Rotation	Top of Pulley Towards Fluid End
Weight	19 lbs.
Crankshaft Diameter	24mm
Volumetric Efficiency @ 1750	0.95
Mechanical Efficiency @ 1750	0.80

Consult the factory for special requirements that must be met if the pump is to operate beyond one or more of the limits specified above.

PULLEY INFORMATION

Pulley selection and pump speed are based on a 1725 RPM motor and "B" section belts. When selecting desired GPM, allow for a ±5% tolerance on pumps output due to variations in pulleys, belts and motors among manufacturers.

1. Select GPM required, then select appropriate motor and pump pulley from the same line.
2. The desired pressure is achieved by selecting the correct nozzle size that corresponds with the pump GPM.

HORSEPOWER INFORMATION

Horsepower ratings shown are the power requirements for the pump. Gas engine power outputs must be approximately twice the pump power requirements shown above.

We recommend that a 1.1 service factor be specified when selecting an electric motor as the power source. To compute specific pump horsepower requirements, use the following formula:

$$HP = (GPM \times PSI) / 1460$$

P59W PULLEY SELECTION & HORSEPOWER REQUIREMENTS							
PUMP PULLEY	MOTOR PULLEY	RPM	GPM	500 PSI	1000 PSI	1500 PSI	1900 PSI
7.75"	4.25"	910	4.7	1.6	3.2	4.8	6.1
7.75"	4.75"	1025	5.3	1.8	3.6	5.4	6.9
7.75"	5.45"	1190	6.1	2.1	4.2	6.3	7.9
7.75"	5.95"	1305	7.0	2.4	4.8	7.2	9.1
7.75"	6.50"	1450	7.5	2.6	5.1	7.7	9.8
7.75"	7.35"	1750	9.0*	3.1	6.2		

*Intermittent Duty Only

P54W, P58W, P59W & P59MT-0020 PUMP PARTS LIST

A= P54 B= P58 C= P59 D= P59MT-0020

<u>ITEM</u>	<u>PART</u>	<u>DESCRIPTION</u>	<u>QTY.</u>	<u>ITEM</u>	<u>PART</u>	<u>DESCRIPTION</u>	<u>QTY.</u>
1	07180	Crankcase	1	31	06722	Automatic Seal Ring(D)	3
2	07181	Vent/Filler Plugwith Seal	1	32	07768	Support Ring (A)	3
2A	07182	Gasket	1	32	07929	Pressure Ring (B)	3
3	07183	Crankcase Cover	1	32	06253	Support Ring (C, D)	3
4	07184	O-Ring	1	33	07769	Support Ring (A)	3
5	07185	Oil Dipstick	1	33	12124	Support Ring (B)	3
6	01009	O-Ring	1	34	07492	Spring Tension Cap (A, B)	6
7	12249	Plug, 1" BSP	1	34	07326-0100	Spring Tension Cap (C, D)	6
9	07188	Cylinder Screw with Slot	4	35	07906	Valve Spring (A, B)	6
10	07223-0100	Spring Washer	4	35	06017-0100	Valve Spring (C, D)	6
11	07190	Oil Drain Plug	2	36	07491	Valve Plate (A, B)	6
11A	13262	Gasket for drain plug	2	36	06016	Valve Plate (C, D)	6
12	07192	Bearing Cover	2	37	08404	Valve Seat (A, B)	6
13	07193	O-Ring	2	37	06014	Valve Seat (C, D)	6
14	01166	Radial Shaft Seal (A, B)	1	38	07770	O-Ring (A, B)	6
14	01166	Radial Shaft Seal (C, D)	2	38	06015	O-Ring (C, D)	6
14A	08439	Lid (A, B)	1	39	07771	Seal Case (A)	3
15	07760	Cylinder Roller Bearing	2	39	12125	Seal Case (B)	3
15A	06245	Shim 0.2mm	1	39	13386	Seal Case (C)	3
15B	06330	Shim 0.1mm	1	39	06723	Seal Case (D)	3
16	07196	Countersunk Screw	6	40	07489	O-Ring(A)	6
17	07197	Crankshaft Protector (C, D)	1	40	07489	O-Ring(B)	3
18	12122	Crankshaft (A, B)	1	40	07234	O-Ring(C, D)	6
18	13330	Crankshaft (C, D)	1	40A	12126	O-Ring (B Only)	3
19	13331	Woodruff Key	1	43	07772	Plug (A, B)	3
20	07199	Connecting Rod Assembly	3	43	07213	Plug (C, D)	3
20A	01027	Screw with Washer	6	44	07035	O-Ring (A, B)	3
22	07777	Crosshead with Plunger Base	3	44	07214	O-Ring (C, D)	3
23	01031	Crosshead Pin	3	45	07773	Inner Hexagon Screw (A, B)	4
24	07763	Crosshead/Plunger Assy. (A)	3	45	07773	Inner Hexagon Screw (C, D)	2
24	13332	Crosshead/Plunger Assy. (B)	3	45A	13387	Stud Bolt (C, D Only)	2
24	13382	Crosshead/Plunger Assy. (C, D)	3	45B	08040	Hexagon Nut (C, D Only)	2
24A	07778	Plunger Pipe (A)	3	45C	08041	Washer (C, D Only)	2
24A	07021	Plunger Pipe (B)	3	46	07774	Inner Hexagon Screw (A, B)	2
24A	13383	Plunger Pipe (C, D)	3	46	13388	Inner Hexagon Screw (C, D)	2
24B	08456	Tension Screw	3	48	07775	Intermediate Casing (A)	1
24C	07676	Copper Gasket	3	48	12127	Intermediate Casing (B)	1
25	06648	Oil Scraper	3	48	13389	Intermediate Casing (C)	1
26	07206	Radial Shaft Seal	3	48	06724	Intermediate Casing (D)	1
26A	07764	Spacer Sleeve	3	49	01009	O-Ring (A, B, C)	1
29	07765	Valve Casing (A, B)	1	50	07767	Automatic Seal Ring(A)	3
29	13384	Valve Casing (C)	1	50	08477	Grooved Seal (B)	3
29	06721	Valve Casing(D)	1	50	13390	Grooved Seal (C)	3
30	07766	Pressure Ring (A)	3	50	06722	Grooved Seal (D)	3
30	12123	Pressure Ring (B)	3	52	13338	Plug, 3/8" BSP (A, B)	3
30	13385	Pressure Ring (C, D)	3	52	07109	Plug, 1/2" BSP (C, D)	3
31	07767	Automatic Seal Ring (A)	3	52A	12007	O-Ring (A, B)	2
31	08477	Grooved Seal (B)	3	52A	07182	Gasket (C, D)	2
31	06250	Automatic Seal Ring (C)	3	58	08486	Copper Crush Washer (A, B)	1

P54W, P58W, P59W & P59MT-0020 REPAIR KITS

Seal Kits

P54W		# 09167	
<u>Item</u>	<u>Part #</u>	<u>Description</u>	<u>Qty.</u>
31 & 50	07767	Automatic Seal Ring	6
32	07768	Support Ring	3
40	07489	O-Ring	6
49	01009	O-Ring	3

P58W		# 09238	
<u>Item</u>	<u>Part #</u>	<u>Description</u>	<u>Qty.</u>
31 & 50	08477	Grooved Seal	6
32	07929	Support Ring	3
40	07489	O-Ring	3
40A	12126	O-Ring	3
49	01009	O-Ring	3

P59W		# 09317	
<u>Item</u>	<u>Part #</u>	<u>Description</u>	<u>Qty.</u>
31	06250	Automatic Seal Ring	3
32	06253	Support Ring	3
40	07234	O-Ring	6
40A	01009	O-Ring	3
50	13390	Grooved Seal	3

P59MT-0020		# 09508	
<u>Item</u>	<u>Part #</u>	<u>Description</u>	<u>Qty.</u>
31 & 50	06722	Automatic Seal Ring	6
32	06253	Support Ring	3
40	07234	O-Ring	6

Valve Assembly Kits

P54W & P58W		# 09168	
<u>Item</u>	<u>Part #</u>	<u>Description</u>	<u>Qty.</u>
34	07492	Tension Cap	3
35	07906	Valve Spring	3
36	07491	Valve Plate	3
37	08404	Valve Seat	3
38	07770	O-Ring	3

P59W & P59MT-0020		# 09318	
<u>Item</u>	<u>Part #</u>	<u>Description</u>	<u>Qty.</u>
34	07326-0100	Tension Cap	3
35	06017-0100	Valve Spring	3
36	06016	Valve Plate	3
37	06014	Valve Seat	3
38	06015	O-Ring	3

Oil Seal Kit

P54W, P58W & P59W & P59MT-0020		#09202	
<u>Item</u>	<u>Part #</u>	<u>Description</u>	<u>Qty.</u>
26	09202	Radial Shaft Seal	3

P54W, P58W, P59W & P59MT-0020 TORQUE SPECIFICATIONS

<u>Position</u>	<u>Item#</u>	<u>Description</u>	<u>Torque Amount</u>
20A	01027	Connecting Rod Screw	125-150 in.-lbs.
43	07772/07213	Plug	50 ft.-lbs.
45/45A	07773/13387	Inner Hexagon Screw/Stud Nut	35 ft.-lbs.

Pump Mounting Selection Guide

<p>Bushings 01074 24 mm Tapered H Bushing</p>
<p>Pulley & Sheaves 01055 9.75" Cast Iron - 2 gr.-AB Section 01061 7.75" Cast Iron 1 gr. - AB Section 01062 7.75" Cast Iron - 2 gr. - AB Section</p>
<p>Rails 01034 Steel Box Rails (L=9.25" x W=1.18" x H=1.62") 01075 Plated Steel Channel Rails (L=9.00" x W=2.12" x H=2.50")</p>

PUMP SYSTEM MALFUNCTION

<u>MALFUNCTION</u>	<u>CAUSE</u>	<u>REMEDY</u>
The Pressure and/ or the Delivery Drops	Worn packing seals Broken valve spring Belt slippage Worn or Damaged nozzle Fouled discharge valve Fouled inlet strainer Worn or Damaged hose Worn or Plugged relief valve on pump Cavitation pump for restrictions Unloader	Replace packing seals Replace spring Tighten or Replace belt Replace nozzle Clean valve assembly Clean strainer Repair/Replace hose Clean, Reset, and Replace worn parts Check suction lines on inlet of Check for proper operation
Water in crankcase	High humidity Worn seals	Reduce oil change interval Replace seals
Noisy Operation	Worn bearings oil with Cavitation	Replace bearings, Refill crankcase recommended lubricant Check inlet lines for restrictions and/or proper sizing
Rough/Pulsating Operation with Pressure Drop	Worn packing Inlet restriction Accumulator pressure Unloader Cavitation	Replace packing Check system for stoppage, air leaks, correctly sized inlet plumbing to pump Recharge/Replace accumulator Check for proper operation Check inlet lines for restrictions and/or proper size
Pump Pressure as Rated, Pressure Drop at Gun	Restricted discharge plumbing	Re-size discharge plumbing to Flow Rate of Pump
Excessive Leakage	Worn plungers Worn packing/seals Excessive vacuum Cracked plungers Inlet pressure too high	Replace plungers Adjust or Replace packing seals Reduce suction vacuum Replace plungers Reduce inlet pressure
High Crankcase Temperature	Wrong Grade of oil Improper amount of oil in crankcase	Giant oil is recommended Adjust oil level to proper amount

Preventative Maintenance Check-List & Recommended Spare Parts List

Check	Daily	Weekly	50hrs	Every 500 hrs	Every 1500 hrs	Every 3000 hrs
Oil Level/Quality	X					
Oil Leaks	X					
Water Leaks	X					
Belts, Pulley		X				
Plumbing		X				
Recommended Spare Parts						
Oil Change (1 Gallon) p/n 1154			X	X		
Seal Spare Parts (1 kit/pump) (See page 8 for kit list)					X	
Oil Seal Kit (1 kit/pump) (See page 8 for kit list)					X	
Valve Spare Parts (1 kit/pump) (See page 8 for kit list)						X

REPAIR INSTRUCTION - P54W, P58W, P59W, & P59MT-0020 PUMPS

NOTE: Always take time to lubricate all metal and nonmetal parts with a light film of oil before reassembly. This step will ensure proper fit, at the same time protecting the pump nonmetal parts (i.e., the elastomers) from cutting and scoring.



1. With a 22mm socket, remove the three discharge valve plugs (43) from the top of the manifold.



2. With a pair of needle nose pliers, remove the discharge valve cage (34), spring (35) and plate (36).

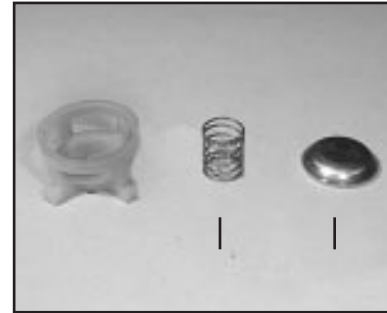

3. Use a slide hammer with a finger attachment to remove the valve seats (37).



4. Inspect the valve seat (37) and valve plate (36) for signs of wear or cavitation and replace as necessary.



5. Using a 8mm allen wrench, remove the inner hexagon screws (45). For P59 pumps, use a crescent wrench to remove the stud nuts (45B).



6. With a rubber mallet tap the back of the valve casing (29) and pull the valve casing (29) off the plungers.



7. Using a 6mm allen wrench, remove the two inner hexagon screws (46).



8. Separate the intermediate casing (48) from the valve casing (29)

REPAIR INSTRUCTION - P54W, P58W, P59W, & P59MT-0020 PUMPS



9. Remove and inspect the weep seal (50) and replace if necessary.

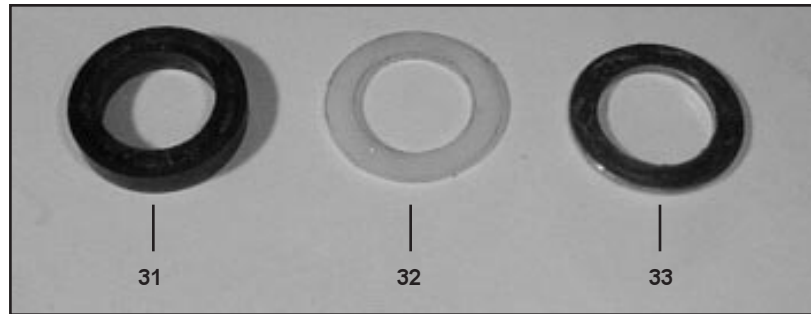

10. Remove and inspect the high pressure seal (31), pressure ring (32) and support ring (33). Replace if needed.

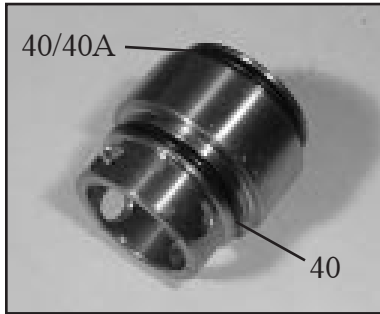

11. Remove the seal case (39) from the valve casing (29) and inspect both o-rings (40 and/or 40A) for wear.



12. Using a needle nose pliers, remove the valve cage (34), spring (35) and valve plate (36) from the valve casing (29). Using a slide hammer with finger attachments, remove the valve seat (37) from the valve casing.

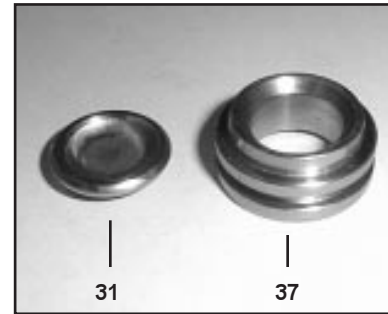

13. Inspect the valve seat (37) and valve plate (36) for wear and cavitation. Replace as needed.



14. Install the inlet valve assembly (34-38) back into the valve casing.



15. Install the seal case (39) with o-rings (40 and/or 40A) into the valve casing (29).

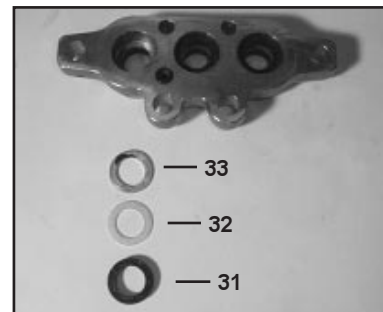

16. Install the high pressure seal (31), pressure ring (32) and support ring (33) into the intermediate casing (48).

REPAIR INSTRUCTION - P54W, P58W, P59W, & P59MT-0020 PUMPS



17. Lubricate the weep seal (50) and install into the intermediate casing (48).

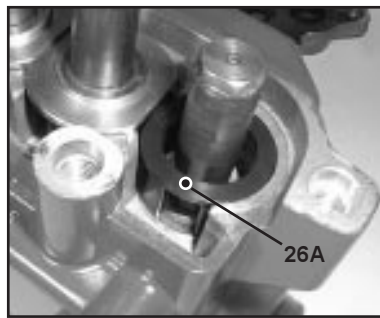

18. Replace the three spacer sleeves (26A) over the plunger with the flanged side toward the valve casing (29).

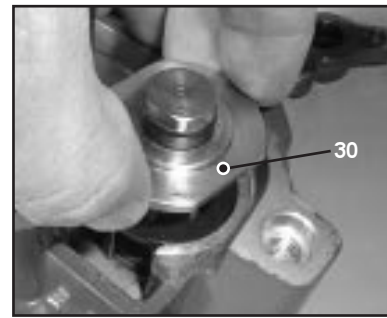

19. Install the pressure rings (30) over the plungers. Make sure that the o-ring (49) is in place.



20. Secure the intermediate casing (48) to the valve casing (29) with the inner hexagon screws (46).



21. Place the valve casing (29) over the plungers. Secure the valve casing with the inner hexagon screws (45). For P59 pumps use the stud nuts (45B). Torque the screws and stud nuts to 35 ft.-lbs.



22. Install the three discharge valve assemblies with o-rings (34 - 38).



23. Replace the discharge plugs (43) and torque to 50 ft.-lbs.

REPAIR INSTRUCTION - P54W, P58W, P59W, & P59MT-0020 PUMPS

Maintenance of the Gear End

24. With the valve casing (29) and intermediate casing (48) off the pump, remove the crankcase cover screws (9). Inspect the crankcase cover (3) and its o-ring (4) for wear. Replace as necessary.
25. Inspect the dipstick (5) vent hole for signs of clogging. Clean as necessary.
26. To remove the crankshaft (18), first remove the bearing cover plates (12). Remove the key (19).
27. Remove the connecting rod caps (20A) with a 5 mm allen wrench and push the connecting rod (20) and plunger rod (22) down as far as possible into the crankcase housing.
28. Hold the pump rear assembly with a wooden fixture or other suitable device, in order to secure it while removing the crankshaft (18). Using a plastic mallet, tap the crankshaft from one side while turning it from the other side. This turning ensures that during this sequence the crankshaft does not become wedged against the connecting rods (20). The far side bearing (15) will remain in the crankcase (1). When free, the crankshaft can be removed by hand. The far side crankshaft seal (14) will be removed by this procedure.
29. If necessary, use a bearing puller to remove the crankshaft bearing (15).
30. Remove the connecting rod and plunger rod/crosshead assembly from the rear of the pump by pulling straight out of the crosshead guides.
31. Using a dowel and rubber mallet, tap the oil seals (26) out from the rear of the crankcase (1).
32. To remove the crosshead pin (23) from the crosshead (22), place the assembly on a wooden fixture to avoid damage to the crosshead. Drive out the pin on the opposite side of the mark on the crosshead. On those pumps without a mark on the crosshead, drive out the pin by tapping out the tapered side of the pin.
33. To remove the bearing (15) remaining in the crankcase (1), insert the small end of a bearing tool and tap with a rubber mallet until the bearing and seal (14) are completely removed. The bearing can only be removed from the inside by inserting a bearing tool through the opposite side of the crankcase. The crosshead guide in the crankcase should be inspected for possible damage.
34. To reassemble, place the far bearing (15) in the crankcase bearing housing. With the bearing tool as a driver, tap into the crankcase using a rubber mallet.
35. Before reinserting into the pump, make sure that the crankshaft seal (14) lip does not show signs of wear and that the garter spring is firmly in place on the seal. With the bearing tool, insert the far side seal. Make sure the seal is firmly seated and well oiled. Replace the bearing cover (12) and tighten securely.
36. Replace the connecting rod (20) and plunger rod/ crosshead assembly by press-fitting the crosshead pin (23). Make sure to insert the beveled edge of the crosshead pin into crosshead. If the crosshead has a mark, install pin from marked side. The crosshead pin should not extend beyond either side of the crosshead in order to prevent damage to the crosshead bore of the crankcase.
37. Generously lubricate (with oil) the crosshead/plunger assembly into the crankcase. Notice that the connecting rod halves are numbered or colored. Position the connecting rods with their numbers or colors on the upper left-hand side, in the same numerical sequence in which they were removed.

REPAIR INSTRUCTION - P54W, P58W, P59W, & P59MT-0020 PUMPS

38. Replace near side bearing (15) on crankshaft (18) by using a bearing tool and mallet to tap into place. Attention must be paid during repair work that the outer bearing ring (15) is placed firmly against the bearing cover (12) on one side. On the opposite side, a correct amount of shims (15A & 15B) are to be inserted between the outer bearing cover (12) and bearing (15) so that the shaft can turn easily with very little clearance.
39. Take the crankshaft end with the bearing and insert the other end through the bearing housing and tap with a rubber mallet until the bearing is seated.
40. When reassembling the connecting rod (20) halves, note that the connecting rod halves are numbered or colored and that the numbers or colors must be matched and aligned. Torque the connecting rod bolts to 125-150 in. lbs.
41. Before installation, apply a small amount of locktite to the O.D. of the crankcase oil seal (26). The oil seal should be installed so that the grooved side of the seal will face the crankcase (1). Tap seal in place using a socket and rubber mallet.
42. Lubricate the weep seal (50) and install into the intermediate casing (48).
43. Replace the three spacer sleeves (26A) over the plunger with the flanged side toward the valve casing (29).
44. Install the pressure rings (30) over the plungers. Make sure that the o-ring (49) is in place.
45. Again lubricate the plungers. Reinstall the intermediate casing (48) and valve casing (29) over the plungers with inner hexagon screws (46).
46. Clean the back edge of crankcase (1) and replace the crankcase cover (3). Be careful not to pinch the crankcase cover o-ring (4).
47. Fill the crankcase (1) with 14 oz. of Giant oil. Check the oil level with the dipstick (5). The oil level should be between the two lines.

P54, P58, P59 & P59MT PUMP DIMENSIONS (inches)

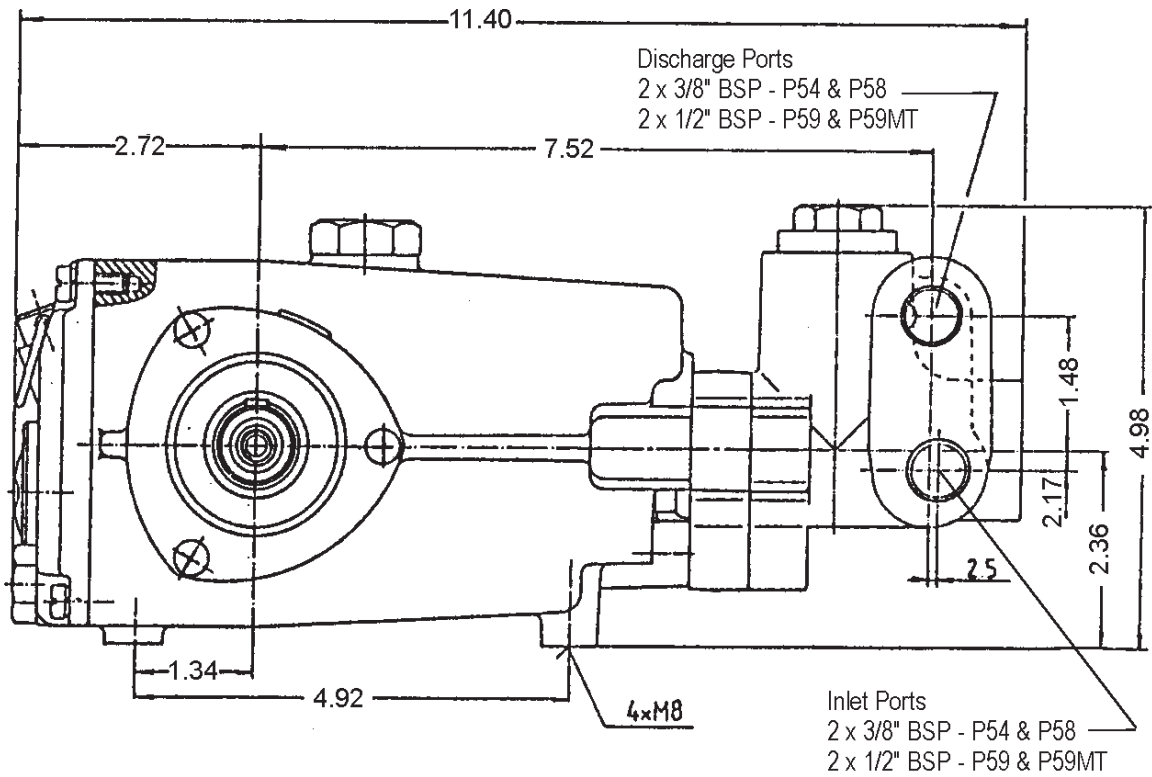
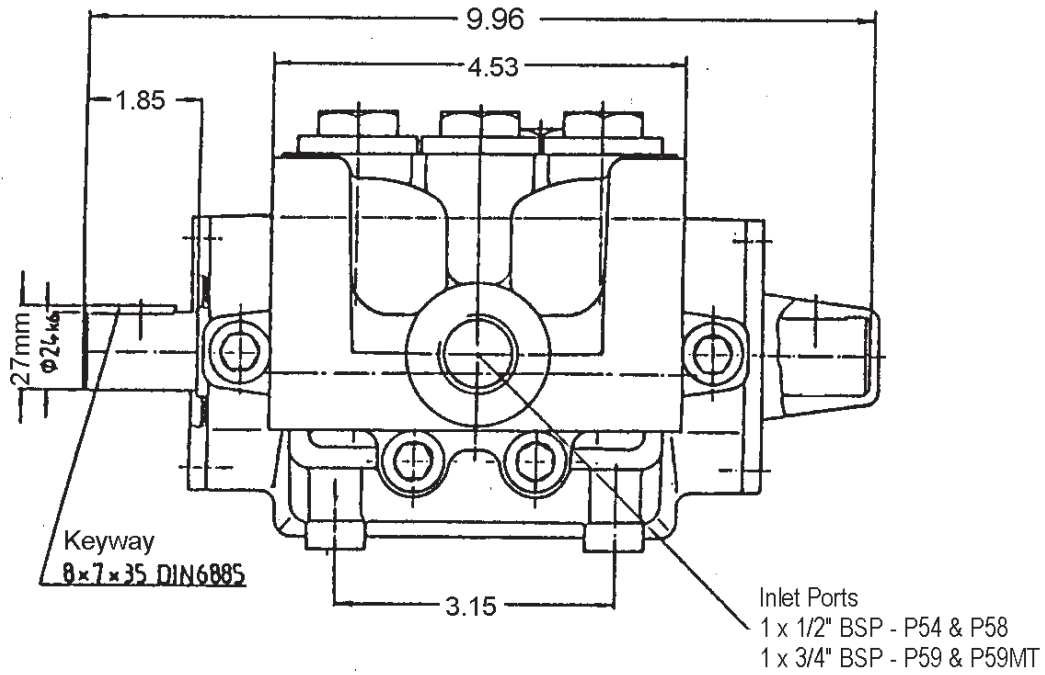

GIANT INDUSTRIES LIMITED WARRANTY

Giant Industries, Inc. pumps and accessories are warranted by the manufacturer to be free from defects in workmanship and material as follows:

1. For portable pressure washers and self-serve car wash applications, the discharge manifolds will never fail, period. If they ever fail, we will replace them free of charge. Our other pump parts, used in portable pressure washers and in car wash applications, are warranted for five years from the date of shipment for all pumps used in NON-SALINE, clean water applications.
2. One (1) year from the date of shipment for all other Giant industrial and consumer pumps.
3. Six (6) months from the date of shipment for all rebuilt pumps.
4. Ninety (90) days from the date of shipment for all Giant accessories.

This warranty is limited to repair or replacement of pumps and accessories of which the manufacturer's evaluation shows were defective at the time of shipment by the manufacturer.

The following items are NOT covered or will void the warranty:

1. Defects caused by negligence or fault of the buyer or third party.
2. Normal wear and tear to standard wear parts.
3. Use of repair parts other than those manufactured or authorized by Giant.
4. Improper use of the product as a component part.
5. Changes or modifications made by the customer or third party.
6. The operation of pumps and or accessories exceeding the specifications set forth in the Operations Manuals provided by Giant Industries, Inc.

Liability under this warranty is on all non-wear parts and limited to the replacement or repair of those products returned freight prepaid to Giant Industries which are deemed to be defective due to workmanship or failure of material. A Returned Goods Authorization (R.G.A.) number and completed warranty evaluation form is required prior to the return to Giant Industries of all products under warranty consideration. Call (419)-531-4600 or fax (419)-531-6836 to obtain an R.G.A. number.

Repair or replacement of defective products as provided is the sole and exclusive remedy provided hereunder and the MANUFACTURER SHALL NOT BE LIABLE FOR FURTHER LOSS, DAMAGES, OR EXPENSES, INCLUDING INCIDENTAL AND CONSEQUENTIAL DAMAGES DIRECTLY OR INDIRECTLY ARISING FROM THE SALE OR USE OF THIS PRODUCT.

THE LIMITED WARRANTY SET FORTH HEREIN IS IN LIEU OF ALL OTHER WARRANTIES OR REPRESENTATION, EXPRESS OR IMPLIED, INCLUDING WITHOUT LIMITATION ANY WARRANTIES OR MERCHANTABILITY OR FITNESS FOR A PARTICULAR PURPOSE AND ALL SUCH WARRANTIES ARE HEREBY DISCLAIMED AND EXCLUDED BY THE MANUFACTURER.