

Triplex Ceramic
Plunger Pump
Operating Instructions/
Repair and Service
Manual

Models

LP122A Series/LP123/LP255

For Models:

LP122A
LP122A-3100
LP122A-4000
LP123
LP255

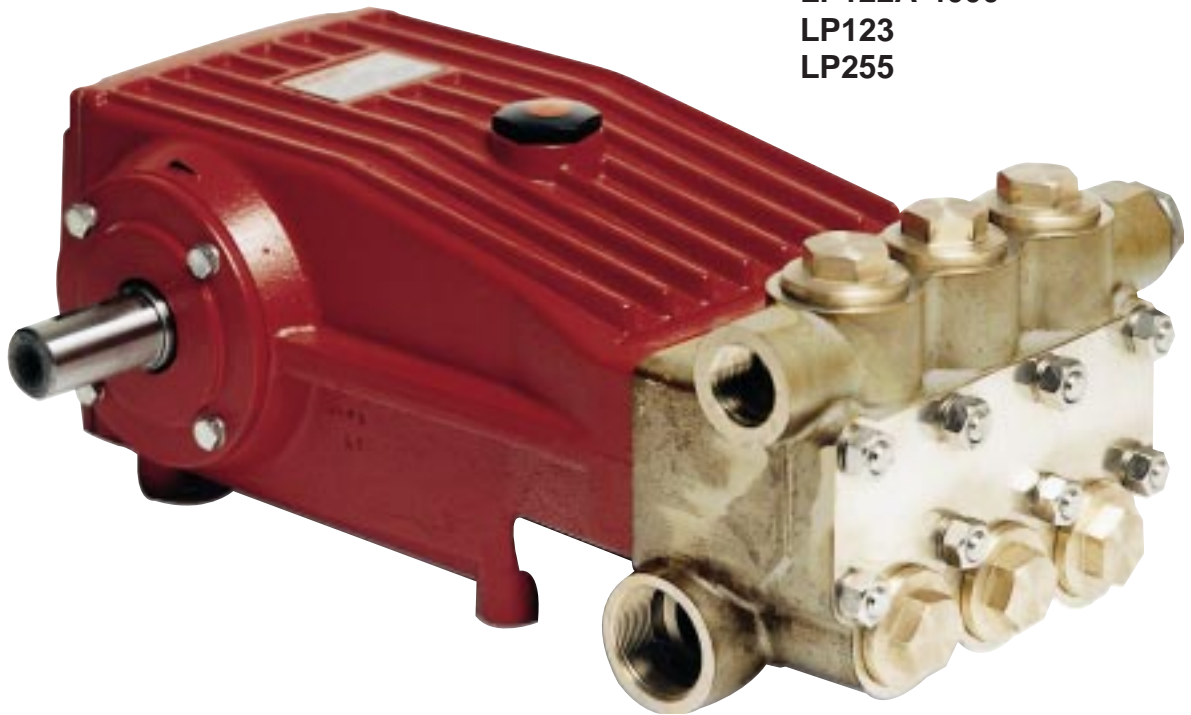

Contents:

Installation Instructions:	page 2
Pump Specifications:	page 3-4
Exploded View:	page 5
Parts List:	page 6
Kit List/Torque Specifications:	page 7
Repair Instructions:	pages 8-10
Dimensions:	page 11
Warranty Information:	back page

INSTALLATION INSTRUCTIONS

Installation of the Giant Industries, Inc., pump is not a complicated procedure, but there are some basic steps common to all pumps. The following information is to be considered as a general outline for installation. If you have unique requirements, please contact Giant Industries, Inc. or your local distributor for assistance.

1. The pump should be installed flat on a base to a maximum of a 15 degree angle of inclination to ensure optimum lubrication.
2. The inlet to the pump should be sized for the flow rate of the pump with no unnecessary restrictions that can cause cavitation. Teflon tape should be used to seal all joints. If pumps are to be operated at temperatures in excess of 160^o F, it is important to insure a positive head to the pump to prevent cavitation. See NPSH curve.
3. The discharge plumbing from the pump should be properly sized to the flow rate to prevent line pressure loss to the work area. It is essential to provide a safety bypass valve between the pump and the work area to protect the pump from pressure spikes in the event of a blockage or the use of a shut-off gun.

4. Use of a dampener is necessary to minimize pulsation at drive elements, plumbing, connections, and other system areas. The use of a dampener with Giant Industries, Inc. pumps is optional, although recommended by Giant Industries, Inc. to further reduce system pulsation. Dampeners can also reduce the severity of pressure spikes that occur in systems using a shut-off gun. A dampener must be positioned downstream from the unloader.

5. Crankshaft rotation on Giant Industries, Inc. pumps should be made in the direction designated by the arrows on the pump crankcase. Reverse rotation may be safely achieved by following a few guidelines available upon request from Giant Industries, Inc. Required horsepower for system operation can be obtained from the charts on pages 3.

6. Before beginning operation of your pumping system, remember: Check that the crankcase and seal areas have been properly lubricated per recommended schedules. Do not run the pump dry for extended periods of time. Cavitation will result in severe damage. Always remember to check that all plumbing valves are open and that pumped media can flow freely to the inlet of the pump.

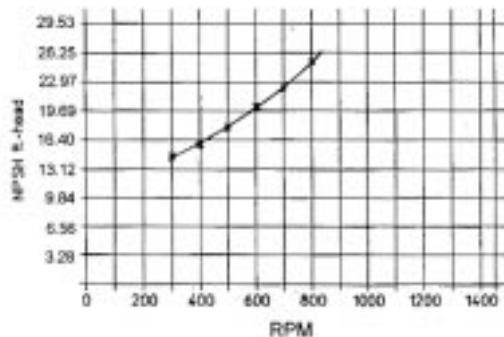

Finally, remember that high pressure operation in a pump system has many advantages. But, if it is used carelessly and without regard to its potential hazard, it can cause serious injury.

IMPORTANT OPERATING CONDITIONS

Failure to comply with any of these conditions invalidates the warranty.

1. Prior to initial operation, add oil to the crankcase so that oil level is between the two lines on the oil dipstick. **DO NOT OVERFILL.**

Use SAE 90 Industrial gear oil

Crankcase oil should be changed after the first 50 hours of operation, then at regular intervals of 500 hours or less depending on operating conditions.

2. Pump operation must not exceed rated pressure, volume, or RPM. A pressure relief device must be installed in the discharge of the system.

3. Acids, alkalines, or abrasive fluids cannot be pumped unless approval in writing is obtained before operation from Giant Industries, Inc.

4. Run the pump dry approximately 10 seconds to drain the water before exposure to freezing temperatures.

Specifications

Models LP122A Series/LP123

Volume	Up to 39.0 GPM (147.6 l/m)
Discharge Pressure	Up to 2000* PSI (138* Bar)
Inlet Pressure	Up to 90 PSI (6.2 Bar)
Speed	Up to 885 RPM
Plunger Diameter	42 mm
Stroke	42 mm
Crankcase Oil Capacity	116 fl.oz.
Temperature of Pumped Fluids	Up to 160°F (71°C)
Inlet Port	1-1/2" NPT
Discharge Port	1" NPT
Crankshaft Mounting	Either Side
Shaft Rotation	Top of Pulley Towards Fluid End
Weight	116 lbs.
Crankshaft Diameter	35 mm
Valve Casing - LP122A	Aluminum Bronze
Valve Casing - LP123	Brass
Valve Casing - LP122A-4000	303 S.S.
Valve Casing - LP122A-3100	Aluminum Bronze-Nickle
Volumetric Efficiency @ 800 RPM.....	0.96
Mechanical Efficiency @ 800 RPM.....	0.85

PULLEY INFORMATION

Pulley selection and pump speed are based on a 1725 RPM motor and "B" section belts. When selecting desired GPM, allow for a ±5% tolerance on pumps output due to variations in pulleys, belts and motors among manufacturers.

1. Select GPM required, then select appropriate motor and pump pulley from the same line.
2. The desired pressure is achieved by selecting the correct nozzle size that corresponds with the pump GPM.

HORSEPOWER INFORMATION

We recommend that a 1.1 service factor be specified when selecting an electric motor as the power source. To compute specific pump horsepower requirements, use the following formula:

$$HP = (GPM \times PSI) / 1440$$

Pump speeds of 640 RPM and above require a minimum inlet pressure of 12 psig.
 Pump speeds of 805 RPM and above require a minimum inlet pressure of 14 psig.

LP122A SERIES/LP123 PULLEY SELECTION AND HORSEPOWER REQUIREMENTS								
GPM	PUMP PULLEY	MOTOR PULLEY	RPM	600 PSI	800 PSI	1000 PSI	1300 PSI	2000 PSI*
22.3	12.75"	3.95"	500	9.6	12.7	15.9	20.7	31.9
24.7	12.75"	4.35"	555	10.6	14.1	17.6	22.9	35.3
28.5	12.75"	4.95"	640	12.2	16.3	20.4	26.5	40.7
30.9	12.75"	5.35"	695	13.2	17.7	22.1	28.7	44.1
33.4	12.75"	5.75"	750	14.3	19.1	23.9	31.0	47.7
35.6	12.75"	6.15"	800	15.3	20.3	25.4	33.1	50.9
39.4*	12.75"	6.50"	885	16.9	22.5	28.1	36.6	56.3

*Intermittent duty only! - Consult factory!

Specifications Model LP255

Volume	Up to 26.0 GPM (147.6 l/m)
Discharge Pressure	Up to 2200*
Inlet Pressure	Up to 90 PSI
Speed	Up to 1000 RPM
Plunger Diameter	32 mm
Stroke	42 mm
Crankcase Oil Capacity	116 fl.oz.
Temperature of Pumped Fluids	Up to 160°F
Inlet Port	1-1/2" NPT
Discharge Port	1" NPT
Crankshaft Mounting	Either Side
Shaft Rotation	Top of Pulley Towards Fluid End
Weight	116 lbs.
Crankshaft Diameter	35 mm
Valve Casing - LP122A	Aluminum Bronze
Valve Casing - LP123/LP255	Brass
Valve Casing - LP122A-4000	303 S.S.
Valve Casing - LP122A-3100	Aluminum Bronze-Nickle
Volumetric Efficiency @ 800 RPM	0.96
Mechanical Efficiency @ 800 RPM	0.85

PULLEY INFORMATION

Pulley selection and pump speed are based on a 1725 RPM motor and "B" section belts. When selecting desired GPM, allow for a ±5% tolerance on pumps output due to variations in pulleys, belts and motors among manufacturers.

1. Select GPM required, then select appropriate motor and pump pulley from the same line.
2. The desired pressure is achieved by selecting the correct nozzle size that corresponds with the pump GPM.

HORSEPOWER INFORMATION

We recommend that a 1.1 service factor be specified when selecting an electric motor as the power source. To compute specific pump horsepower requirements, use the following formula:

$$HP = (GPM \times PSI) / 1440$$

LP255 PULLEY SELECTION AND HORSEPOWER REQUIREMENTS							
PUMP PULLEY	MOTOR PULLEY	RPM	GPM	1000 PSI	1500 PSI	2000 PSI	2200 PSI
12.75"	3.95"	500	13	9.3	13.9	18.6	20.4
12.75"	4.35"	640	16.6	11.9	17.8	23.7	26.1
12.75"	4.95"	750	19.5	13.9	20.9	27.9	30.6
12.75"	5.35"	805	20.9	14.9	22.4	29.9	32.8
12.75"	5.75"	865	22.5	16.1	24.1	32.1	35.4
12.75"	6.15"	920	23.9	17.1	25.6	34.1	37.6
12.75"	6.50"	1000	26	18.6	27.9	37.1	40.9

*Intermittent duty only! - Consult factory!

Exploded View - LP122A Series/LP123/LP255

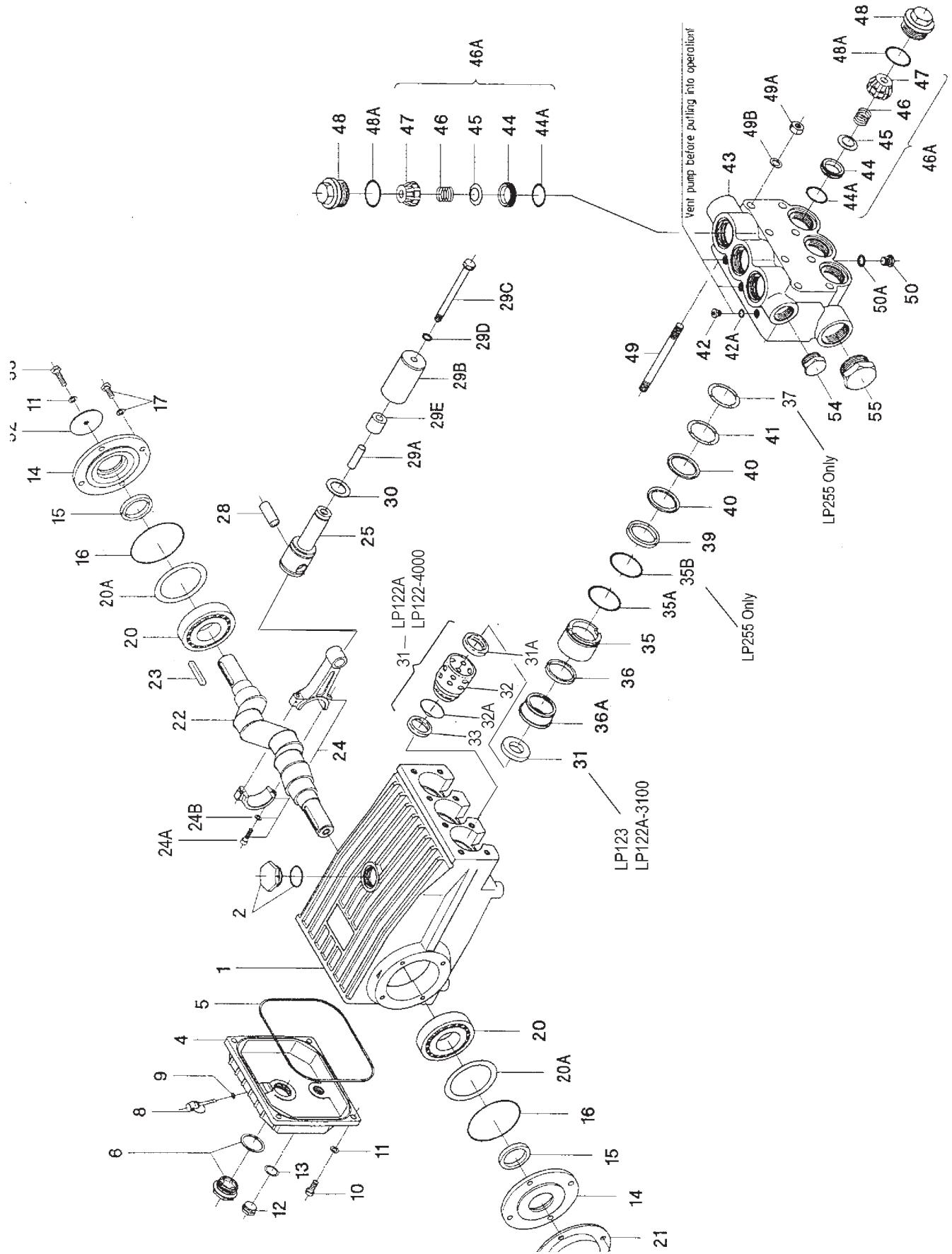

LP122A SERIES/LP123/LP255 PARTS LIST

A = LP122A B = LP123 C = LP122-4000 D = LP122A-3100 E = LP255

ITEM	PART NO.	DESCRIPTION	QTY.	ITEM	PART NO.	DESCRIPTION	QTY.
1	07759	Crankcase	1	35B	13141	O-Ring (E only)	3
2	13000	Oil Filler Plug	1	36	13415	V-Sleeve, Weep (A-D)	3
4	06085	Crankcase Cover	1	36	13025	V-Sleeve, Weep (E)	3
5	07104	O-Ring	1	36A	13416	Pressure Ring, Weep, (A, B, C)	3
6	07186	Oil Sight Glass W/Gasket	1	36A	13416-0100	Pressure Ring, (D)	3
8	06086	Oil Dipstick	1	36A	06700	Pressure Ring (E)	3
9	01009	O-Ring	1	37	06701	Support Disc (E only)	3
10	01010	Screw, (A, B, C, E)	4	39	07744	Pressure Ring, (A, B, C)	3
10	08093	Screw, (D)	4	39	07744-0100	Pressure Ring, (D)	3
11	01011	Spring Washer, (A, B, C)	5	39	13026	Pressure Ring (E)	6
11	08094	Spring Washer, (D)	5	40	07745	V-Sleeve (A, B, C, D)	6
12	07109	Oil Drain Plug, (A, B, C, E)	1	40	13027	V-Sleeve (E)	6
12	12137	Oil Drain Plug, (D)	1	41	07746	Support Ring, (A, B, C)	3
13	07110	Gasket, (A, C)	1	41	06621-0100	Support Ring, (D)	3
13	07182	Gasket, (B, D, E)	1	41	06702	Support Ring (E)	3
14	07111	Bearing Cover	2	42	06589	Plug, (D only)	3
15	07112	Crankshaft Seal	2	42A	07204-0100	Steel Ring, (D only)	3
16	07113	O-Ring	2	43	13343	Valve Casing, (A)	1
17	07114	Hex Screw, (A, B, C, E)	8	43	06625	Valve Casing, (B)	1
17	08095	HexScrew, (D)	8	43	13343-4000	Valve Casing, (C)	1
20	07116	Taper Roller Bearing	2	43	13343-3000	Valve Casing, (D)	1
20A	07117	Fitting Disc, 0.1mm	2	43	06703	Valve Casing, (E)	1
20B	13001	Fitting Disc, 0.15mm	3	44	07748	Valve Seat, (A, B, C, E)	6
21	07118	Shaft Protector	1	44	07748-0100	Valve Seat, (D)	6
22	13242	Crankshaft	1	44A	07150	O-Ring, (A, B, C, E)	6
23	13243	Key	1	44A	06620	O-Ring, (D)	6
24	13340	Connecting Rod Assy.	3	45	07749	Valve Plate, (A, B, C, E)	6
24A	13277	Hex Screw	6	45	07749-0100	Valve Plate, (D)	6
24B	13278	Spring Washer	6	46	07750	Valve Spring	6
25	13341	Crosshead Plunger		46A	07751	Valve Assy. Complete, (A, B, C, E)	
		Base Assy.	3			(#44, 44A, 45, 46, & 47)	6
28	13232	Crosshead Pin	3	46A	07751-0100	Valve Assmbeley Complete (D)	
29A	07735	Centering Sleeve	3			(#44, 44A, 45, 46, & 47)	6
29B	07736	Plunger Pipe (A-D)	3	47	07752	Spring Retainer	6
29B	13022	Plunger Pipe (E)	3	48	07753	Plug, (A)	6
29C	07737	Plunger Bolt, (A, B, C, E)	3	48	06504	Plug, (B, E)	6
29C	07737-0100	Plunger Bolt, (D)	3	48	06089	Plug, (C, D)	6
29D	07755	Copper Gasket, (A, B, C, E)	3	48A	12055	O-Ring, (A, B, C, E)	6
29D	07761-0100	Gasket for Bolt, (D)	3	48A	06577	O-Ring, (D)	6
29E	06087	Spacer Pipe, (A, B, C, E)	3	49	07157	Stud Bolt	8
29E	06618	Spacer Pipe, (D)	3	49A	07158	Nut	8
30	07789	Flinger (A, B, C, D)	3	49B	07159	Washer	8
30	07779	Flinger (E)	3	50	07423	Plug, (A,B, E)	1
31	06120	Seal Retainer, Complete, (A, C)	3	50	07423-0100	Plug, (C, D)	1
31A	06118	Oil Seal, (A, C)	3	50A	07161	Gasket, (A, B,C, E)	1
31B	07133	Radial Shaft Seal, (B, D, E)	3	50A	07755-0100	Gasket, (D)	1
32	06116	Oil Seal Retainer, (A, C)	3	52	13020	Disk for Crankshaft	1
32A	06119	O-Ring, (A, C)	3	53	06607	Hexagon Screw	1
33	06117	Backup Seal, (A, C)	3	54	07756	Plug 1" NPT, (A, C)	1
35	13342	Seal Sleeve, (A, B, C)	3	54	06626	Plug 1" NPT, (B, E)	1
35	13342-0100	Seal Sleeve, (D)	3	54	13321-0100	Plug 1" BSP, (D)	1
35	06699	Seal Sleeve (E)	3	55	07757	Plug 1-1/2" NPT, (A, C)	1
35A	07740	O-Ring, (A, B, C, E)	3	55	06627	Plug, 1-1/4" NPT, (B, E)	1
35A	06619	O-Ring, (D)	3	55	13322-0100	Plug, 1" BSP, (D)	1

NOTE: For LP122 pumps manufactured prior to 5/94, and needing weep seal replacement, change the pressure ring (36) to the newer style (p/n 13416) and use the new style weep seal (p/n 13415) in your pumps.

LP122A SERIES/LP123/LP255 PUMP REPAIR KITS

Plunger Packing Kit # 09477 (LP122A, LP123, LP122A-4000) *(for pumps manufactured after 4/98)*

<u>Item</u>	<u>Part #</u>	<u>Description</u>	<u>Qty.</u>
35A	07740	O-ring	3
36	13415	V-Sleeve, Weep	3
40	07745	V-Sleeve	6

Valve Assembly Kit LP122A, LP123, LP122A-4000, LP255 #09136

<u>Item</u>	<u>Part #</u>	<u>Description</u>	<u>Qty.</u>
46A	07751	Valve Assembly, Complete	3
48A	12055	O-Ring	3

Plunger Packing Kit # 09535 (LP255)

<u>Item</u>	<u>Part #</u>	<u>Description</u>	<u>Qty.</u>
35A	07740	O-ring	3
35B	13141	O-Ring	3
36	13025	V-Sleeve weep	3
40	13027	V-Sleeve	6

Valve Assembly Kit LP122A-3100 #09305

<u>Item</u>	<u>Part #</u>	<u>Description</u>	<u>Qty.</u>
46A	07751-0100	Valve Assembly Complete	3
48A	06577	O-Ring	3

LP122A SERIES/LP123/LP255 TORQUE SPECIFICATIONS

<u>Position</u>	<u>Item#</u>	<u>Description</u>	<u>Torque Amount</u>
10	01010/08093	Screw, Cover	125 in.-lbs.
17	07114/08095	Hex Screw, Bearing Cover	125 in.-lbs.
24A	13277	Hex Screw, Connecting Rod	250 in.-lbs.
29C	07737/07737-0100	Plunger Bolt	26 ft.-lbs.
48	07753/06504/06089	Plug, Valve	160 ft.-lbs.
49A	07158	Nut, Stud Bolt	60 ft.-lbs.

LP122A Series/LP123 - Repair Instructions



1. With a 30mm wrench, remove the six (6) plugs (48) from the valve casing (43). Inspect the o-rings (48A) and replace if necessary. Remove the complete valve assembly (46A) by threading a 12mm bolt into the spring retainer and pulling straight out.

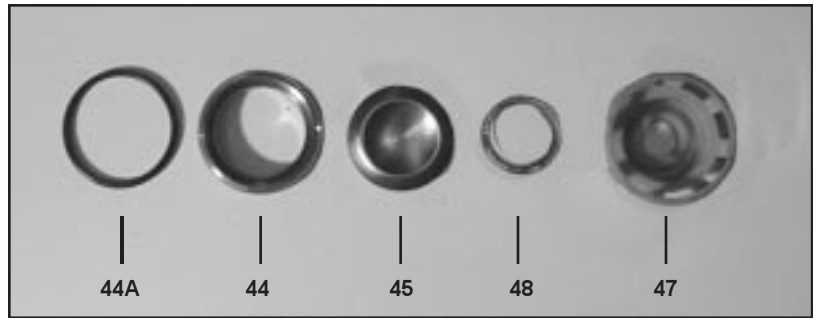

2. To disassemble the valve, screw the bolt into the retainer until the valve plate (45) presses the valve seat (44) out of the spring retainer. Examine all parts and replace if necessary. If the seat doesn't come out, use a valve puller to remove.

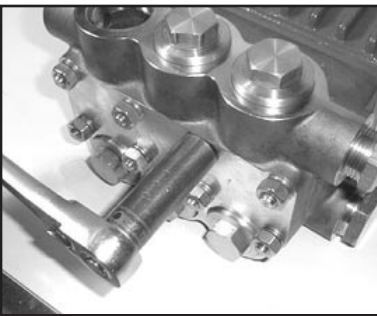

3. Remove the eight (8) hex nuts (49A) with a 19mm wrench. Tap the back of the manifold (43) with a rubber mallet to dislodge and slide off the studs.

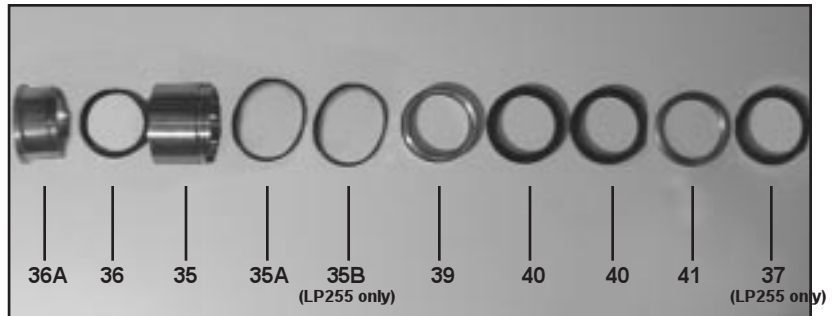

4. Remove the seal sleeve (35) from the manifold and/or crankcase. Remove the pressure rings (39&36A), v-sleeves (40&36), support ring (41) and o-rings (35A and 35B in Lp255A only) from the manifold and seal sleeve, respectively. For LP255 only, remove support ring (37). Examine seals carefully and replace if worn. Clean all parts.

5. If there are signs of oil leaking through the plunger oil seals, then replacement is necessary. For LP122A & LP122A-4000, remove the plunger pipe (29B) before inspecting oil seals (31A & 33). For the LP123 & LP122A-3100 disassemble the gear end and push out the seals from the back of the pump.

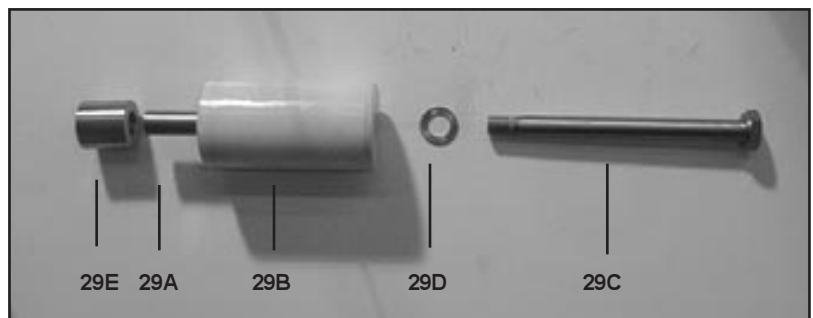

6. Inspect surface of plunger pipe (29B) carefully. Remove any chemical or mineral deposits taking care not to damage the surface of the plunger. If plunger pipe is worn, remove the plunger bolt (29C), plunger pipe (29B) and spacer (29E). Replace worn parts necessary. **Note: Always use a new copper gasket (29) when repairing the plunger assembly.**



7. For LP122A & LP122A-4000 pumps, oil seal replacement can be accomplished by pulling the retainer forward out of the crankcase. The o-ring around the outside of the retainer should be replaced and lubricated with a light film of



oil.
8. The back-up seal (33) can be pried out of the back of the retainer (32) with a small screwdriver. To replace with new seal, lubricate edges of new seal, then squeeze outside edges of seal, forcing the seal to collapse into a figure 8. Tuck the two outside edges of the figure 8 into the rear of the retainer, making sure that the inner lip of the seal faces the oil. The seal may now be pressed firmly into place.



9. The front oil seal (31A) can now be removed by inserting a screwdriver through the rear of the retainer and tapping the seal out through the front of the retainer. Remove any excess old loc-tite from retainer. To replace oil seal, apply a light film of loc-tite around outside edges of seal. Tap seal firmly into the retainer with a wooden dowel making certain that the spring side of the seal is installed first and that the seal sits squarely in the retainer.

TO REASSEMBLE PROCEED AS FOLLOWS:



10. For LP122A & LP122A-4000 pumps, generously lubricate the inside of the oil seals (31A & 33) and o-ring (32A). Next, place the seal retainer, complete (31) over the steel plunger base seat firmly into the crankcase. Replace the flinger (30).

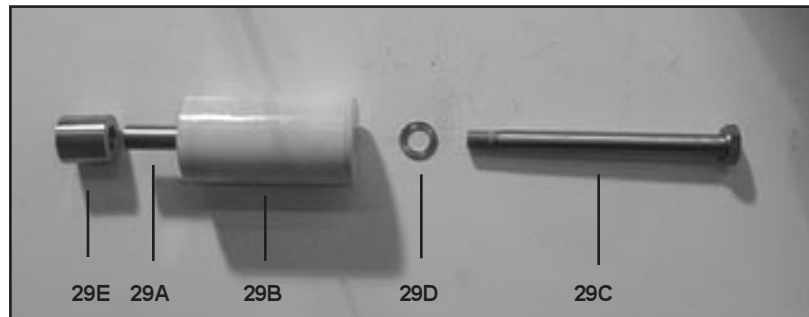

11. If previously disassembled thoroughly clean all exposed surfaces on the spacer (29E) and all exposed threads on the plunger bolt (29C) and the steel plunger base (25). Threads **MUST** be free of old loc-tite and any other material such as oil, grease, etc. This is necessary to ensure proper curing of new loc-tite. Giant recommends cleaning the threads with acetone or other suitable cleaner. Reassemble plunger assembly parts (29A, 29B, & 29E) using a new copper gasket (29D) and the cleaned plunger bolt (29C). Slide the bolt through the center of the four (4) pieces so that the threaded end is exposed. Apply several drops of loc-tite 243 (or equivalent) adhesive to the threads. Thread into steel plunger base and tighten to 26 ft.-lbs. **BE CERTAIN ALL PARTS ARE CENTERED WITH THE BOLT!**

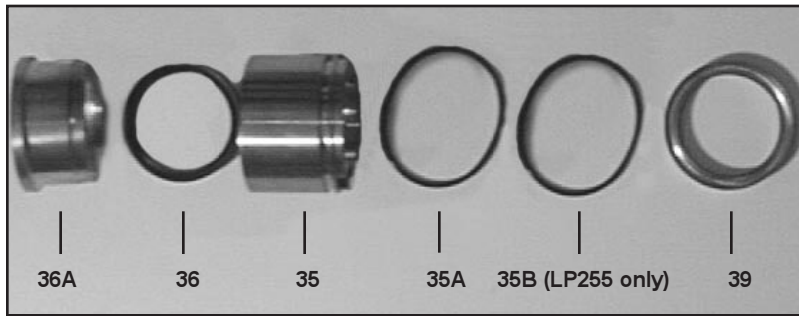

12. Lubricate weep seal (36). Place weep seal (36), and pressure ring (36A) into the seal sleeve (35). Assemble the o-ring (35A and 35B for LP255 only) onto seal sleeve and lubricate.



14. Press seal sleeve assembly into the manifold and seat firmly. Put the support ring (41) on plunger with v-side facing the manifold.

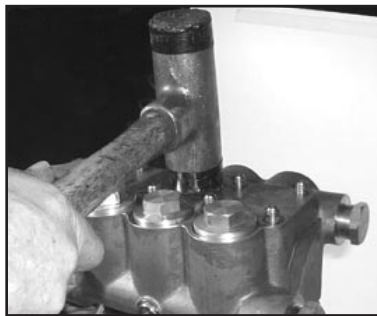

15. Place entire manifold/seal sleeve assembly over the studs and push firmly until seated against the crankcase.



17. Next, place valve assemblies (46A) into manifold after first lubricating the o-ring (44A). Seat



18. Replace plug with o-ring (48, & firmly into manifold.



13. For LP255 pumps, insert support ring (37) into valve casing (43). Place support ring (41) and v-sleeves (40) into valve casing.

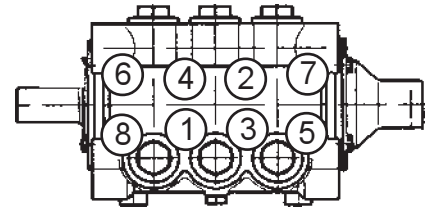

16. Tighten hex nuts (49A) in a crosswise pattern (shown above) to 60 ft.-lbs.

48A) and tighten to 160 ft.-lbs.
19. Fill crankcase with approximately 116 fluid ounces of Giant oil or equivalent SAE 90 industrial gear oil and check oil level of the crankcase with the dipstick. Proper level is center of two lines. Reinstall your Giant LP pump into your system.

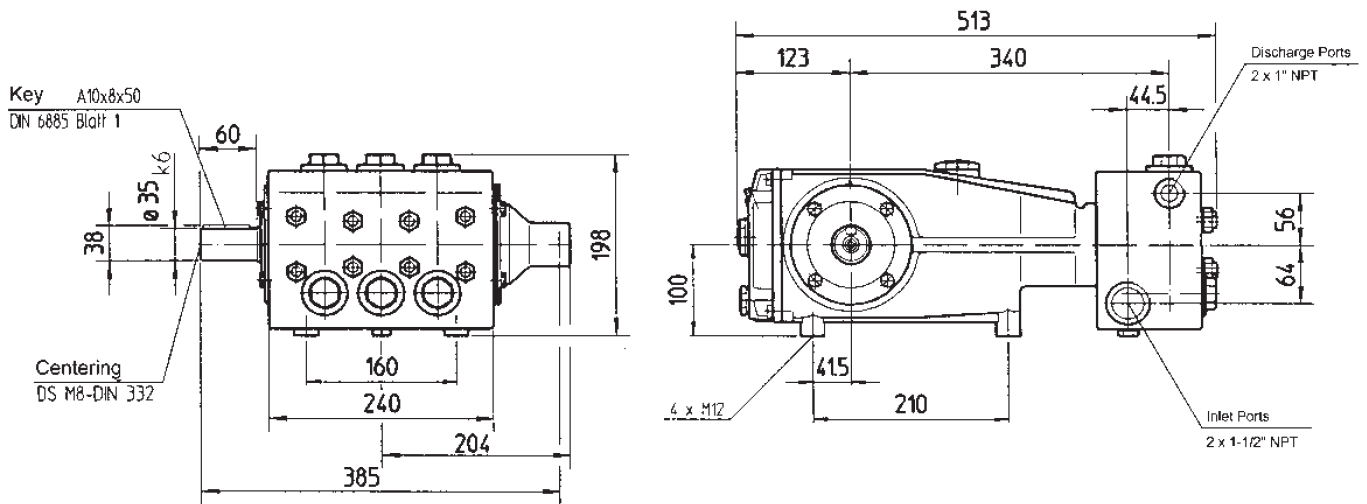
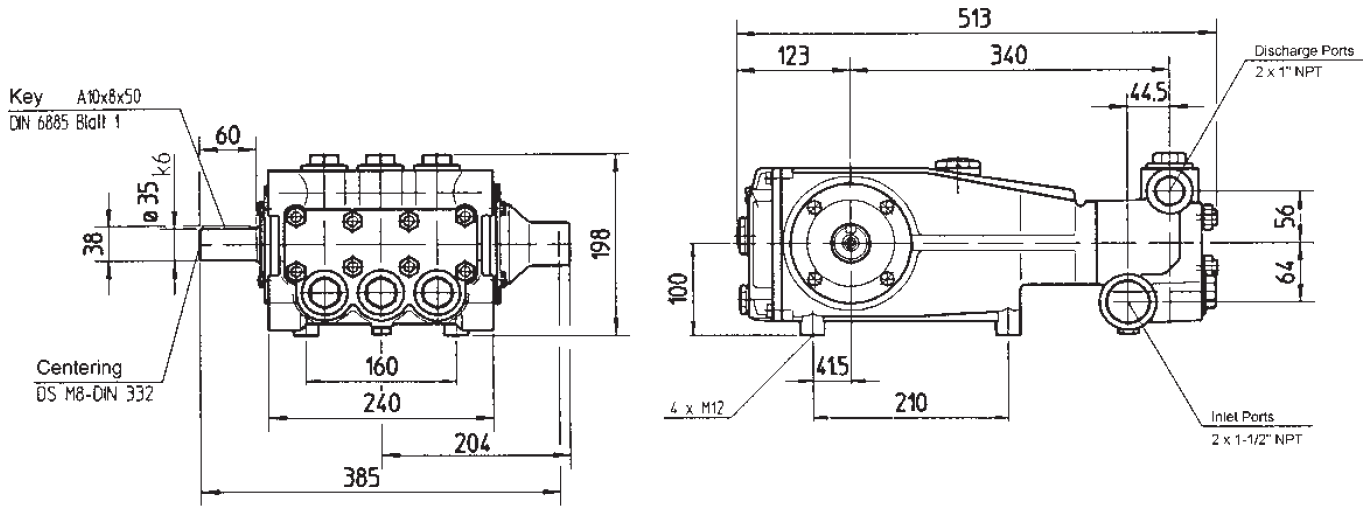

GIANT INDUSTRIES LIMITED WARRANTY

Giant Industries, Inc. pumps and accessories are warranted by the manufacturer to be free from defects in workmanship and material as follows:

1. For portable pressure washers and self-service car wash applications, the discharge manifolds will never fail, period. If they ever fail, we will replace them free of charge. Our other pump parts, used in portable pressure washers and in car wash applications, are warranted for five years from the date of shipment for all pumps used in NON-SALINE, clean water applications.
2. One (1) year from the date of shipment for all other Giant industrial and consumer pumps.
3. Six (6) months from the date of shipment for all rebuilt pumps.
4. Ninety (90) days from the date of shipment for all Giant accessories.

This warranty is limited to repair or replacement of pumps and accessories of which the manufacturer's evaluation shows were defective at the time of shipment by the manufacturer. The following items are NOT covered or will void the warranty:

1. Defects caused by negligence or fault of the buyer or third party.
2. Normal wear and tear to standard wear parts.
3. Use of repair parts other than those manufactured or authorized by Giant.
4. Improper use of the product as a component part.
5. Changes or modifications made by the customer or third party.
6. The operation of pumps and or accessories exceeding the specifications set forth in the Operations Manuals provided by Giant Industries, Inc.

Liability under this warranty is on all non-wear parts and limited to the replacement or repair of those products returned freight prepaid to Giant Industries which are deemed to be defective due to workmanship or failure of material. A Returned Goods Authorization (R.G.A.) number and completed warranty evaluation form is required prior to the return to Giant Industries of all products under warranty consideration. Call (419)-531-4600 or fax (419)-531-6836 to obtain an R.G.A. number.

Repair or replacement of defective products as provided is the sole and exclusive remedy provided hereunder and the MANUFACTURER SHALL NOT BE LIABLE FOR FURTHER LOSS, DAMAGES, OR EXPENSES, INCLUDING INCIDENTAL AND CONSEQUENTIAL DAMAGES DIRECTLY OR INDIRECTLY ARISING FROM THE SALE OR USE OF THIS PRODUCT.

THE LIMITED WARRANTY SET FORTH HEREIN IS IN LIEU OF ALL OTHER WARRANTIES OR REPRESENTATION, EXPRESS OR IMPLIED, INCLUDING WITHOUT LIMITATION ANY WARRANTIES OR MERCHANTABILITY OR FITNESS FOR A PARTICULAR PURPOSE AND ALL SUCH WARRANTIES ARE HEREBY DISCLAIMED AND EXCLUDED BY THE MANUFACTURER.