

FEATURES

- The preferred pump frame in the pressure cleaning industry
- Forged brass manifold with an exclusive lifetime warranty
- Large-capacity, die-cast, anodized aluminum oil-bath crankcase
- Over-sized connecting rods for maximum life
- Heavy-duty tapered roller bearing.
- Solid ceramic plungers with continuously lubricated packings
- Unitized stainless steel inlet and discharge valves
- Available in left-handed "L" version



SPECIFICATIONS

Pump Model	T1011		TS1021		TS2021-N	
Maximum Volume (GPM)	4.5	5.6	4.5	5.6	4.5	5.6
Max. Discharge Pressure (PSI)	2000	1500	3000	1700	3500	3500
Maximum Pump Speed (RPM)	1125	1450	1125	1450	1125	1450
Maximum Inlet Pressure	125 PSI					
Maximum Inlet Vacuum	9 ft. water (7.9 in. Hg)					
Bore	.787 in. / 20 mm					
Stroke	.630 in. / 16 mm					
Crankcase Oil Capacity	33.8 oz		40.6 oz..			
Maximum Fluid Temperature	165°F					
Inlet Port Thread	1/2-14 BSPP-F					
Discharge Port Thread	3/8-19 BSPP-F					
Shaft Diameter.	.945 in. / 24 mm					
Weight	32 lbs.					
Dimensions	12.2 x 9.2 x 6.9 in.					

N=Nickel-plated manifold

DIMENSIONAL DRAWING

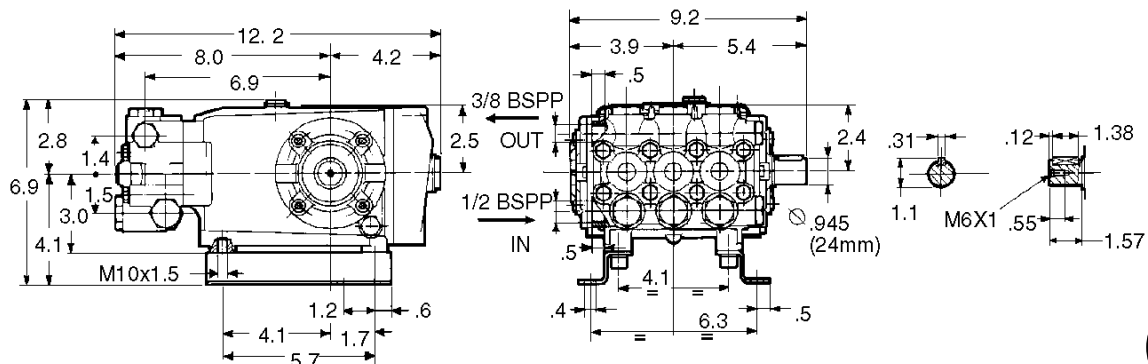

T Series 47 S – 20 mm x 16 mm

GENERAL PUMP

A member of the Interpump Group

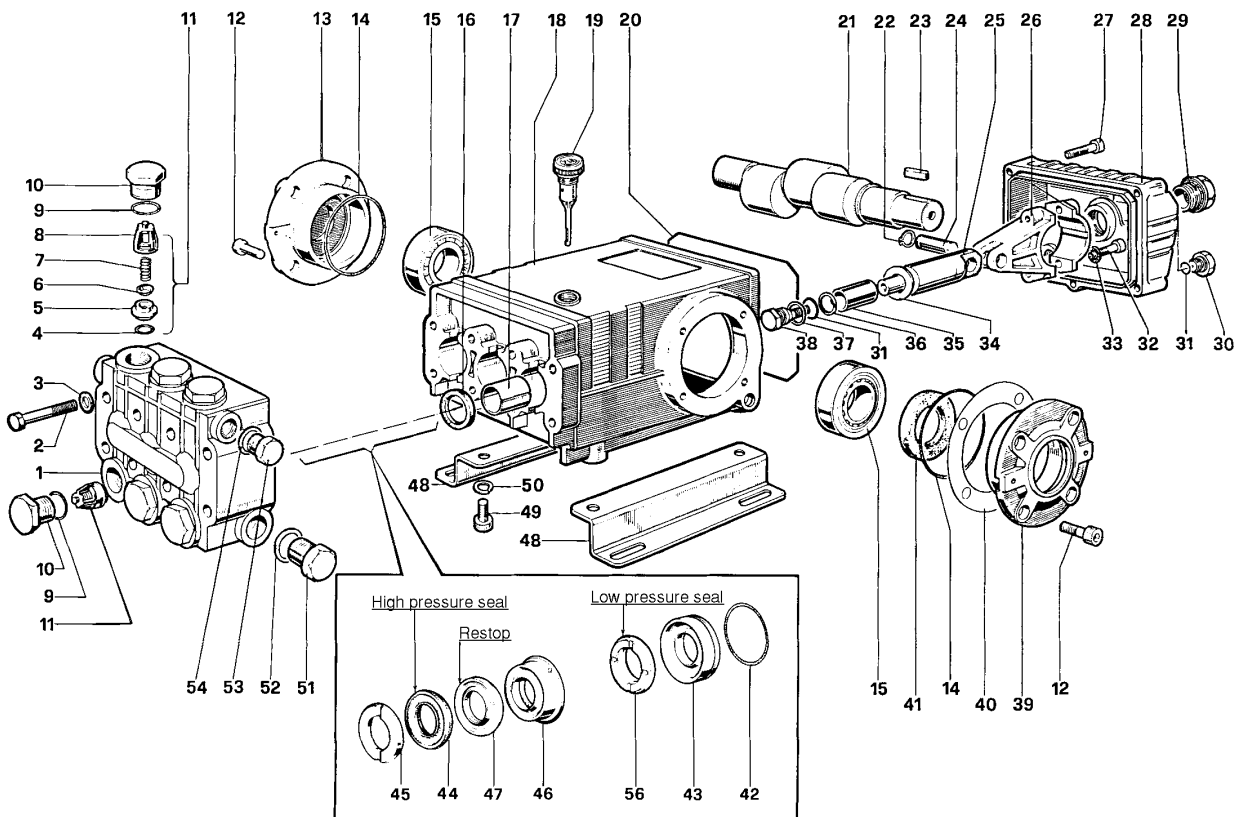

PARTS LIST

ITEM	PART NO.	DESCRIPTION	KIT NO.	QTY.	ITEM	PART NO.	DESCRIPTION	KIT NO.	QTY.	ITEM	PART NO.	DESCRIPTION	KIT NO.	QTY.
1	47120841	Manifold		1	19	98210600	Oil Dip Stick		1	37	96728000	Washer	6	3
	47120941	Manifold, Nickel-Plated (TS2021-N)		1	20	90392200	O-Ring, Cover		1	38	47219566	Screw, Plunger	6	3
2	99320600	Screw, M8 x 70		8	21	47021735	Crankshaft		1	39	47150022	Cover, Crankcase		1
3	96702000	Washer, M8.4		8	22	90055700	Ring, Snap		6	40	97567800	Shim		2
4	90384100	O-Ring, .674 x .103	1	6	23	91489000	Key		1	41	90164800	Seal, Oil	3	1
5	36200366	Seat, Valve	1	6	24	97738000	Pin, Wrist		3	42	90361600	O-Ring, 1.364 x .070	10, 28	3
6	36200176	Plate, Valve	1	6	25	47050554	Guide, Plunger		3	43	47080570	Retainer, Packing	10, 28	3
7	94737600	Spring	1	6	26	47030001	Rod, Connecting		3	44	90270500	Packing	28, 69	3
8	36200251	Guide, Valve	1	6	27	99191200	Screw, M6 x 30		5	45	47100051	Ring, Head, M20	7, 28	3
9	90384700	O-Ring, .797 x .103	4, 5	6		99183700	Screw, M6 x 14 (T1011)		5	46	47216970	Intermed. Ring	28, 71	3
10	98222000	Cap	4	6	28	47160122	Cover, Crankcase		1	47	90270400	Restop Ring	28, 69, 71	3
	98222200	Cap, Ni-Plated (TS2021-N)	5	6		47160022	Cover, Crankcase (T1011)		1	48	47200074	Pump Feet		2
11	36703201	Valve Assembly	1	6	29	97596800	Oil Indicator		1	49	99364400	Screw, M10 x 18		4
12	99303900	Screw, M8 x 16		8	30	98204100	Cap		1	50	96710600	Washer, M10.2		4
13	47150122	Cover, Crankcase		1	31	90358500	O-Ring, .426 x .070	6	4	51	98217600	Cap		1
14	90391300	O-Ring, 2.675 x .103		2	32	99309900	Screw, M8 x 35		6	52	96751400	Washer, M21.5		1
15	640047	Bearing, Roller		2	33	96701400	Washer, M8.4		6	53	98210000	Cap		1
16	90162500	Seal, Oil	2	3	34	96728600	Washer, M14	6	3	54	96738000	Washer, M17.5		1
17	90912600	Bushing		3	35	47040409	Plunger, (20 mm)		3	56	90271000	Seal, Low Press., 20mm	28, 69	3
18	47010522	Crankcase		1	36	90506700	Ring, Back-up	6	3					

REPAIR KITS

KIT NO.	1	2	3	4	5	6	7	10	28	69	71
ITEM NO.s INCLUDED IN KIT	4, 5 6, 7, 8 (11)	16	41	9, 10	9, 10	31, 34, 36, 37, 38	45	42, 43	42, 43, 44, 45, 46, 47, 56	44, 47, 56	46, 47
NUMBER OF ASSEMBLIES IN KIT	6	3	2	6	6	3	6	3	1	3	3
NUMBER OF CYLINDERS KIT WILL SERVICE	3	3	-	3	3	3	3	3	1	3	3

TORQUE SPECS*

Position	Ft.-lbs.
2	22.1
10	73.7
12	14.7
27	7.3
29	13.2
30	14.7
32	14.7
38	14.7
49	29.4
51	29.4
53	29.4

*Decrease torque by 20% if threads are lubricated.

