



# KIL

# Owner's Manual

- *Installation*
- *Use*
- *Maintenance*



# INDEX

page

1. INTRODUCTION	1
2. GENERAL WARNINGS FOR SAFE OPERATION	1
a. Fluid injection hazard	1
b. Fuel and emission hazards: engine driven products	2
c. Grounding instructions: motor driven products	2
d. Extension cords: motor driven products	3
e. Equipment misuse hazard	3
f. Hose safety	3
g. Moving parts hazard	4
h. Terms	4
3. PUMP IDENTIFICATION	5
4. TECHNICAL FEATURES	5
5. CONSTRUCTION FEATURES	6
6. GENERAL INFORMATION ON PUMP USE	7
a. Water temperature	7
b. Pump performance	7
7. CONNECTIONS AND PLUGS	7
8. PUMP INSTALLATION	8–9
a. Positioning	8
b. Direction of rotation	8
c. Hydraulic connections	8
d. Pump feeding	8
e. Suction line	8
f. Filtration	9
g. Delivery line	9
9. START-UP AND RUNNING PROCEDURES	10
a. Start-up checks	10
b. Start-up and operation	10
c. Cooling system	10
10. MAINTENANCE INSTRUCTIONS	10–17
a. Crank mechanism maintenance	10
b. Fluid end maintenance	11
c. Pressure packings and plunger maintenance	11–12
d. Fastener torque values	12
e. Parts breakdown	14–17
11. PUMP STOPPED FOR LONG PERIOD	13
12. FROST PRECAUTIONS	13
13. KL MODELS	13

## 1. INTRODUCTION

The General Pump KL series of high pressure plunger pumps have been designed for long life. They will provide a long period of trouble free operation, if they are correctly installed and maintained.

**Read this manual carefully before using your pump.** It contains necessary information for correct installation, use and maintenance, and practical trouble shooting suggestions.

## 2. GENERAL WARNINGS FOR SAFE OPERATION



**WARNING:** The misuse of a high pressure water unit and improper pump installation and maintenance increases the risk of personal injury and serious damage to the equipment.



**WARNING:** High pressure spray can cause serious injury. For professional use only. Observe all warnings.



**WARNING:** Read and understand all instruction manuals before operating equipment.

### 2a. Fluid injection hazard

#### General safety

This pump generates very high fluid pressure. Spray from a gun, leaks or ruptured components can inject fluid through your skin and into your body and cause extremely serious bodily injury including the need for amputation. Also, fluid injected or splashed into the eyes or on the skin can cause serious damage.

- **Never** point the spray gun or wand at anyone or at any part of the body. **Never** put hand or fingers over the spray tip.
- **Always** follow the **PRESSURE RELIEF PROCEDURE**, **before** cleaning or servicing any part of the system.
- **Never** try to stop or deflect leaks with your hand or body.
- Be sure all equipment safety devices are operating properly before each use.
- **Always** install a pressure relief valve sized to discharge (bypass) 110% of the maximum pump flow rate.
- Protect all components from environmental damage and high pressure water spray.
- **Always** restrict access to the area to properly trained and required personnel.
- Keep the area clear of debris and loose items.
- **Always** use only genuine General Pump replacement parts when servicing the pump.

#### Medical treatment

If any fluid appears to penetrate your skin, get **EMERGENCY MEDICAL TREATMENT AT ONCE. DO NOT TREAT AS A SIMPLE CUT.** Tell the doctor exactly what fluid was injected.

**NOTE TO PHYSICIAN:** *Injection in the skin is a traumatic injury. It is important to treat the injury surgically as soon as possible. Do not delay treatment to research toxicity. Toxicity is a concern with some exotic coatings injected directly into the bloodstream. Consultation with a plastic surgeon or reconstructive hand surgeon may be advisable.*

### Pressure relief procedure

To reduce the risk of serious bodily injury, including fluid injection and splashing in the eyes or on the skin, always follow this procedure whenever you stop spraying for more than 10 minutes, when shutting down, and before checking or repairing any part of the system.

1. Engage the trigger safety latch.
2. Turn the system off.
3. Disconnect the power supply.
4. Shut off the water supply.
5. Disengage the trigger safety latch and trigger the gun to relieve pressure, and then engage the trigger safety latch again.
6. Before long-term (overnight) storage, disconnect the water supply and disconnect the power supply.

### Spray gun safety devices

Be sure all gun safety devices are operating properly before each use. Do not remove or modify any part of the gun; this can cause a malfunction and result in serious bodily injury.

**Safety latch:** Whenever you stop spraying for a moment, always set the gun safety latch in the engaged or “safe” position, making the gun inoperative. Failure to properly set the safety latch can result in accidental triggering of the gun.

**Spray tip safety:** Use extreme caution when cleaning or changing spray tips. If a spray tip clogs while spraying, engage the gun safety latch immediately. **Always** follow the **PRESSURE RELIEF PROCEDURE** and then remove the spray tip to clean it.

### 2b. Fuel and emission hazards: engine driven products

**Never** fill the fuel tank while the unit is running or hot. The fuel used in this unit is combustible and when spill on a hot surface can ignite and cause a fire. **Always** fill tank slowly to avoid spilling.

**Never** operate the unit in a closed building. The exhaust contains carbon monoxide, a poisonous, odorless, invisible gas which can cause serious injury or death if inhaled.

**Never** alter the maximum throttle setting, which is factory set. Tampering with this adjustment can damage the pressure washer and will void the warranty.

### 2c. Grounding instructions: motor driven products

This product must be grounded. If it should malfunction or break down, grounding provides a path of least resistance for electric current to reduce the risk of electric shock. If the equipment is equipped with a cord having an equipment-grounding conductor and a grounding plug, the plug must be plugged into an appropriate outlet that is properly installed and grounded in accordance with all local codes and ordinances.



**DANGER:** Improper connection of the equipment-grounding conductor can result in the risk of electrocution. Check with a qualified electrician or service person if you are in doubt as to whether an outlet is properly grounded. Do not modify any plug provided with the product – if it will not fit the outlet, have a proper outlet installed by a qualified electrician.

## 2d. Extension cords: motor driven products

Use only 4-wire extension cords that have 4-prong grounding-type plugs and 4-pole cord connectors that accept the plug from the product. Use only extension cords that are intended for outdoor use. These extension cords are identified by a marking, "Acceptable for use with outdoor appliances; store indoors while not in use." Use only extension cords having an electrical rating not less than the rating of the product. Do not use damaged extension cords. Examine extension cord before using and replace if damaged. Do not abuse extension cord and do not yank or pull on any cord to disconnect. Keep cord away from heat and sharp edges. Always disconnect the extension cord from the receptacle before disconnecting the product from the extension cord.



**WARNING:** To reduce the risk of electrocution, keep all connections dry and off the ground. Do not touch plug with wet hands.

## 2e. Equipment misuse hazard

### General safety

Any misuse of the pump or accessories, such as overpressurizing, modifying parts, using incompatible chemicals and fluids, or using worn or damaged parts, can cause them to rupture and result in fluid injection, splashing in the eyes or on the skin, or other serious bodily injury, fire, explosion or property damage.

**Never** alter or modify any part of this equipment; doing so could cause it to malfunction.

**Check** all equipment regularly and repair or replace worn or damaged parts immediately.

**Always** wear protective eyewear, hearing protection and appropriate clothing. If using a chemical, read and follow the chemical manufacturer's literature for recommendations on additional protective equipment, such as a respirator.

### System pressure

This pump can develop high operating pressure. Be sure that all equipment and accessories are rated to withstand the maximum working pressure of this system. **Do not** exceed the maximum working pressure of any component or accessory used in the system.

### Chemical compatibility

**Be sure** that all chemicals used are compatible with the wetted parts as given in the Technical Data. Always read the chemical manufacturer's literature before using any chemical.

## 2f. Hose safety

High pressure fluid in the hoses can be very dangerous. If the hose develops a leak, split or rupture due to any kind of wear, damage or misuse, the high pressure spray emitted from it can cause a fluid injection injury or other serious bodily injury or property damage.

**ALL FLUID HOSES MUST HAVE STRAIN RELIEFS ON BOTH ENDS.** The strain reliefs help protect the hose from kinks or bends at or close to the coupling, which can result in hose rupture.

**Tighten** all fluid connections securely before each use. High pressure fluid can dislodge a loose coupling or allow high pressure spray to be emitted from the coupling.

**Never** use a damaged hose. Before each use, check entire hose for cuts, leaks, abrasion, bulging cover, or damage or movement of the hose couplings. If any of these conditions exist, replace the hose immediately.

**Do not** try to recouple high pressure hose or mend it with tape or any other device. A repaired hose cannot contain the high pressure fluid.

**HANDLE AND ROUTE HOSES CAREFULLY.** Do not pull on hoses. Do not use chemicals which are not compatible with the inner tube and cover of the hose. **Do not** expose hose to temperatures above 200° F (93° C) or below -40° F (-40° C).

## 2g. Moving parts hazard

Moving parts can pinch or amputate fingers or other body parts. **Keep clear** of moving parts when starting or operating the system.

**Never** operate the system without all guards and interlocks installed and functioning. Follow the **PRESSURE RELIEF PROCEDURE** before checking or servicing the pressure washer to prevent discharging high pressure fluid from the gun.

## 2h. Terms

**WARNING** or **DANGER:** Alerts user to avoid or correct conditions that could cause bodily injury.

**CAUTION:** Alerts user to avoid or correct conditions that could cause damage to the equipment.

**NOTE:** Identifies helpful procedures and information.

**IMPORTANT:** United States Government safety standards have been adopted under the Occupational Safety and Health Act. These standards – particularly the General Standards, Part 1910, and the Construction Standards, Part 1926 – should be consulted.

### 3. PUMP IDENTIFICATION

Each pump is fitted with a rating plate. The specifications stamped on it are as follows:

- pump model and version
- maximum rpm
- maximum pressure and volume
- crankcase oil capacity and specification
- serial number

The pump model, pump version and serial number data must be specified when ordering spare parts. If the pump is modified, any change should be mentioned on the rating plate for future reference.

### 4. TECHNICAL FEATURES

The pump features:

- three horizontal plungers and six different bore sizes
- vertically-arranged valves
- double V-shaped pressure packings lubricated by a water drip feed system
- splash lubricated crank mechanism
- pulley, flexible joint or PTO shaft drive capabilities

### PUMP MODELS

MODEL	RPM*	Volume	Pressure	Power	
		GPM	PSI	KW	HP
<b>KL30</b>	1000	22.2	2600	29.1	39.6
<b>KL33</b>	1000	27	2150	29.2	39.8
<b>KL36</b>	1000	32.2	1750	27.5	37.4
<b>KLS40</b>	880	35	2000	26.9	36.6
<b>KL45</b>	800	40.1	1450	29.1	39.6
<b>KL50</b>	700	43.3	1150	25	34

FEATURES	
• Stroke	1.574 in (40 mm)
• Minimum Inlet Pressure	15 psi
• Maximum Inlet Pressure	45 psi
• Maximum Inlet Water Temperature	150° F
• Oil Capacity	120 oz. (3.75 qts.)
• Weight	154 lbs.

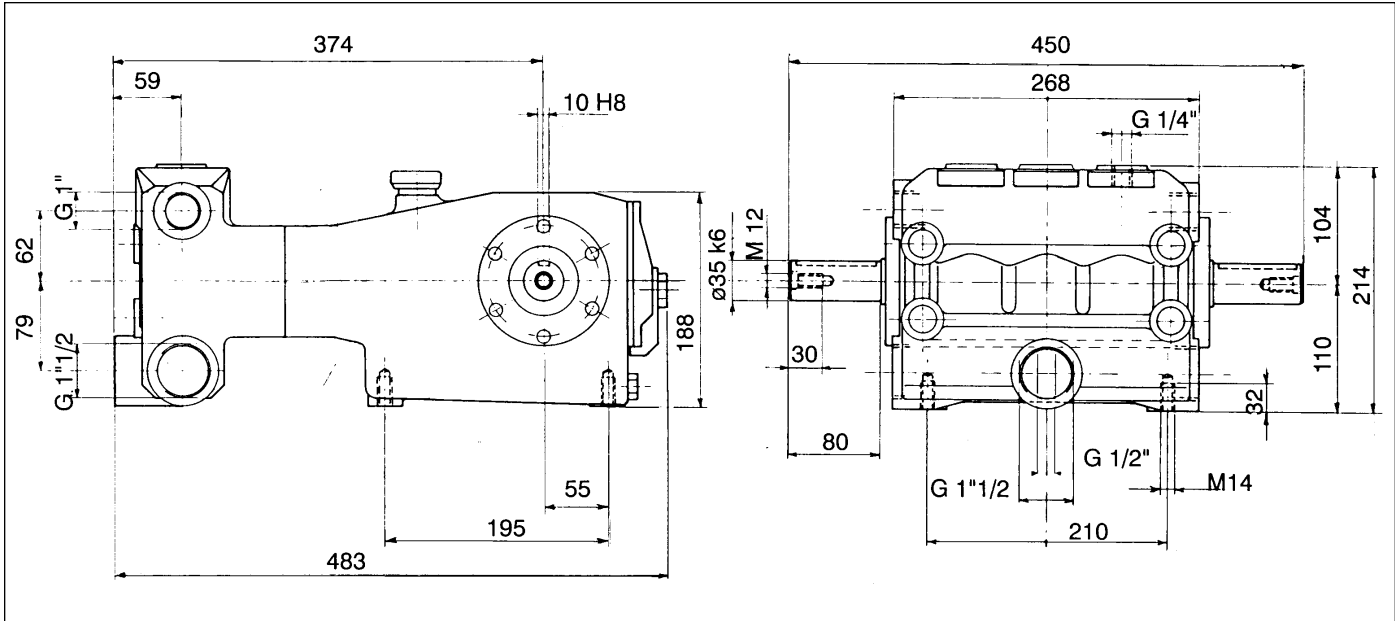

## 5. CONSTRUCTION FEATURES

The main components of the pump consist of:

- A. crank mechanism
- B. plunger and packing system
- C. manifold

**A. CRANK MECHANISM** Includes the cast iron crankcase containing the drive system components:

- gas-nitrided, hardened and tempered alloy steel crankshaft mounted on self-adjusting double roller shaft bearings.
- forged split connecting rods with special anti-friction bearings.
- surface-treated steel piston guides.
- splash lubricated by the pump crankcase oil.

**B. PLUNGER AND PACKING SYSTEM** Primarily composed of ceramic-coated stainless steel plungers and pressure packings with packing supports and cylinders.

**C. MANIFOLD** Contains the suction and high pressure valves, made of stainless steel and bronze (KLZ, KLN and KLA versions are stainless steel). Valve components come out as a single unit.

## 6. GENERAL INFORMATION ON PUMP USE

The KL pump has been designed to pump, at room temperature, fresh, filtered water or other liquids of similar viscosity that are compatible with the wetted materials (for questionable liquids contact our Technical Department).

### 6a. Water temperature.

The maximum inlet water temperature is 150° F.

### 6b. Pump performance

Never exceed the maximum pump flow rate or pressure.

## 7. CONNECTIONS AND PLUGS

The KL series pumps have:

- A. **1-1/2" Inlet Ports (3)** Water supply connection to either or both ports is acceptable.
- B. **1"-NPT Outlet Ports (2)** Both ports can be connected to the delivery line, depending on the accessories to be installed and discharge line characteristics.
- C. **Outlet Port (3)** 1/2"
- D. **Oil Drain Plug (1)** (Ref. D) Used to empty the crankcase during oil changes. It includes a magnet to collect metal impurities inside the crankcase.
- E. **Oil Level Indicators (2)** (Ref. E)

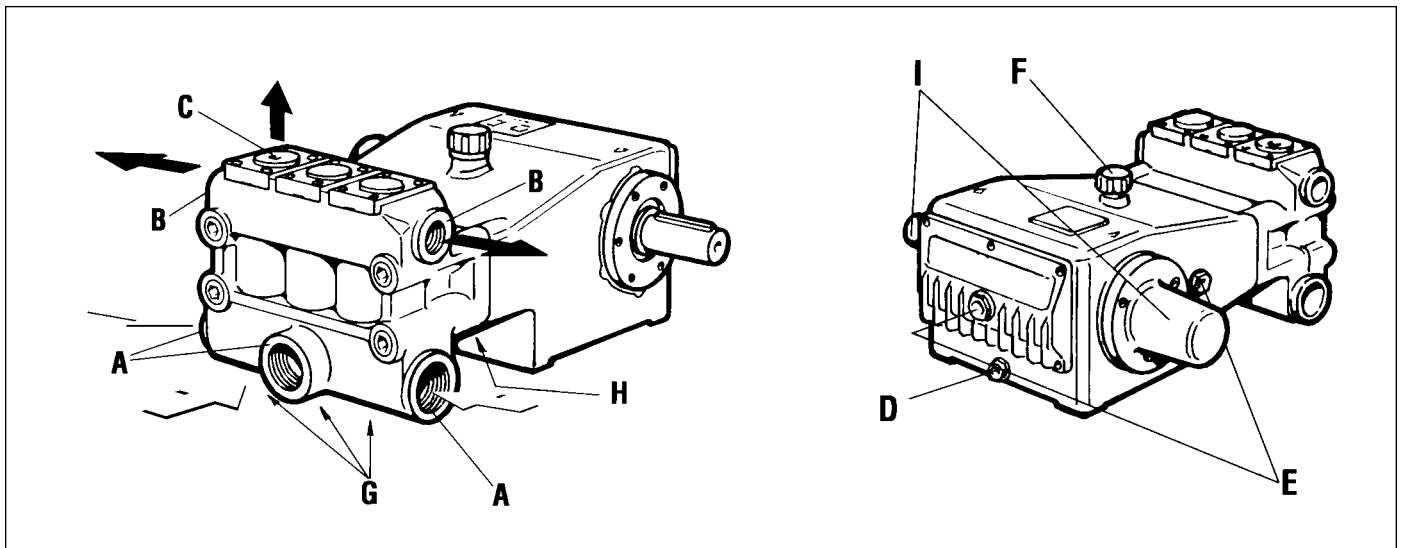

- F. **Oil Fill Plug (1)** (Ref. F) Used to change or add oil.
- G. **Plug (3)** (Ref. G) Used to remove the valve assembly from its seat if it is stuck due to excessive scaling. Remove plugs and insert a pin to dislodge the valve assembly and push it out.
- H. **1/2"-NPT Drain Hole** (Ref. H) Used to drain water from the pressure packing chamber. Always leave this hole open.
- I. **Shaft Projections (2)** 35 mm diameter, the one not being used should be protected by the cover (Ref. I).

## 8. PUMP INSTALLATION

### 8a. Positioning

The pump must be mounted to a rigid and flat base using the four threaded feet in the crankcase.

Be sure maximum pump inclination during operation does not exceed 5° from level in order to guarantee the correct splash lubrication.

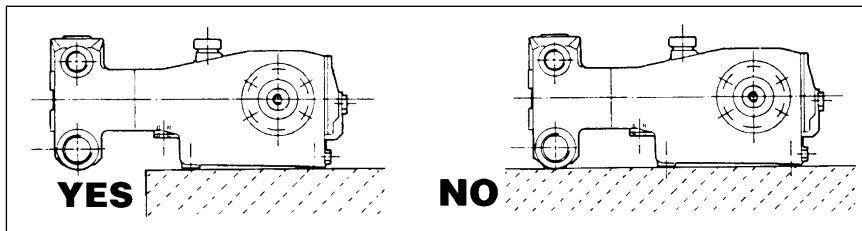

The base must not permit any misalignment or flexing of the pump/transmission coupling.

Never install the pump such that the fluid end rests on the base on which the pump is mounted. The fluid end must be left free and not subject to any force.

### 8b. Direction of rotation

The diagram at right shows the correct direction of rotation looking at the pump from the **fluid end side**:

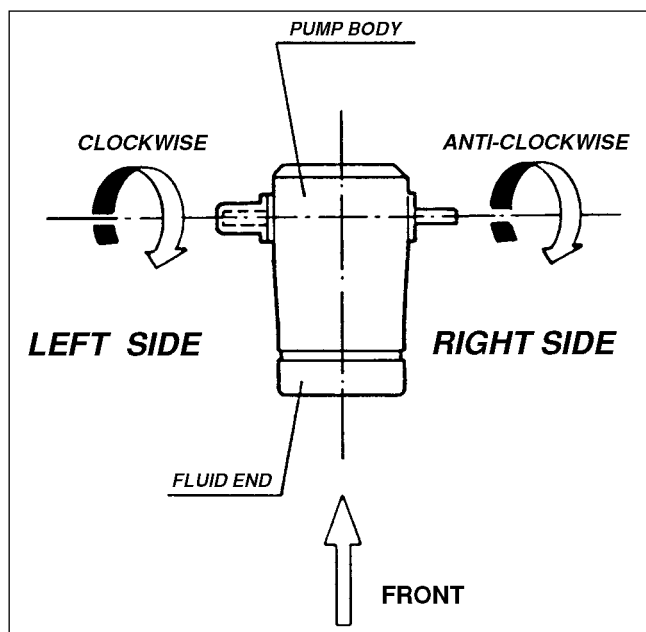

### 8c. Water line connections

In order to isolate the pump vibration, use flexible hoses for both inlet and discharge lines.

### 8d. Pump feeding

KL pumps require an inlet pressure at the inlet port between 15 psi and 45 psi.

The feed pump (centrifugal type) must: (1) supply at least twice the plunger pump volume at the required pressure, (2) operate independently and (3) supply its full rated performance even if the plunger pump is run below its rated performances.

We recommend a pressure switch in the inlet line (after the filters) to prevent the KL pump from starting until the inlet pressure has reached 15 psi. This pressure switch will also stop the pump in case of filter clogging.

### 8e. Inlet line

THE INLET LINE **MUST** HAVE THE FOLLOWING CHARACTERISTICS:

- Minimum internal diameter of 40 mm (1.574 in.).
- No bends or changes in diameter within 12 inches of the suction port.
- Be airtight.
- Be completely free of 90° elbows, diameter reductions, counter slopes and T-connections, and must not be connected with other pipelines within 10 diameters of inlet port.
- Be positioned so that it remains filled after the pump stops.

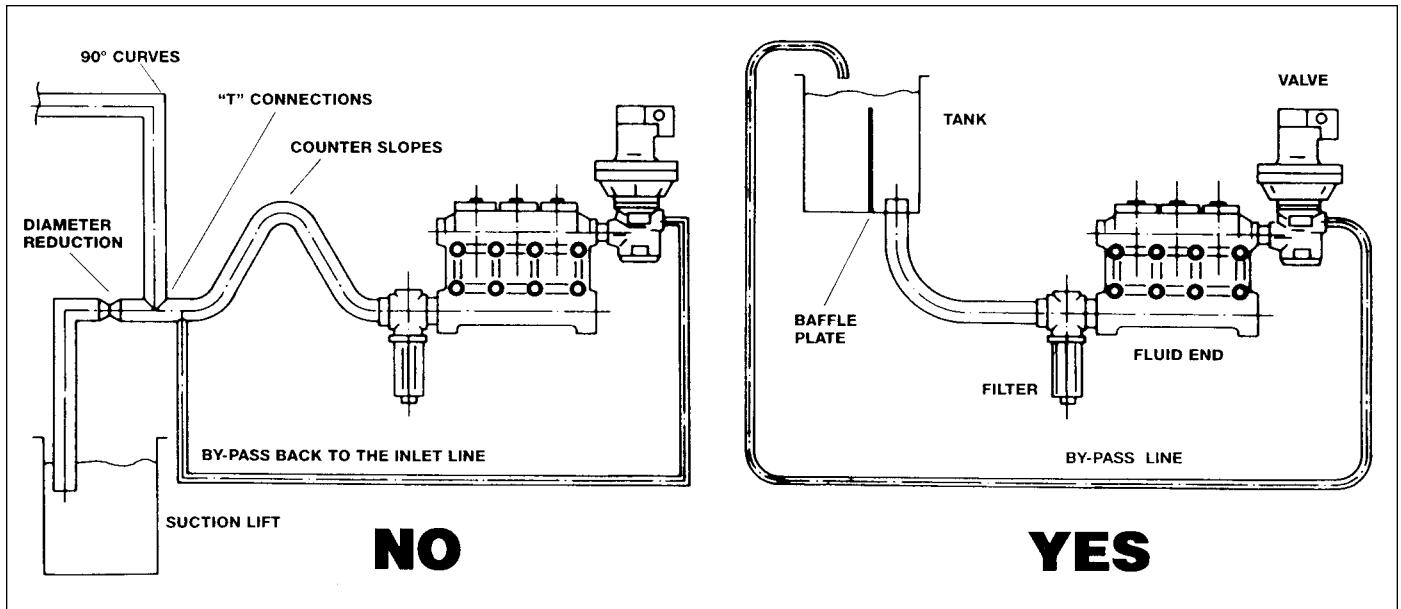

## RECOMMENDATIONS:

- Do not connect the bypass line directly to the inlet line.
- Do not use high pressure flexible hose for the inlet line.
- Install the inlet pressure gauge after the filters and as close as possible to the pump inlet port.
- Be sure that the feed pump tank dimensions and the minimum water level do not create turbulence at the pump inlet port. Recommended minimum tank volume is five times discharge flow rate.
- Connect the by-pass directly to the feed tank and be sure that both the by-pass and feed tank flows do not create turbulence at the pump inlet port. Baffle plates should be inside the tank.
- Before connecting the suction line to the pump inlet port be sure the line is clean inside.
- Do not install a chemical injector on the inlet line.

### 8f. Filtration

KL pumps require 200 to 360 micron filtration.

The filters should be installed as close as possible to the pump, allow easy inspection and have the following characteristics:

- The capacity of each filter must be at least 3 times the rated pump volume.
- Filter port diameters should not be smaller than the pump inlet ports.

**IMPORTANT NOTE:** Clean the filters daily, more often in poor water conditions, to prevent premature pump wear and damage.

### 8g. Discharge line

To ensure the discharge line is correctly installed:

- Install a suitable safety valve on the discharge line.
- Use only high pressure hoses and fittings that exceed the working pressure of the system.
- Use glycerine filled pressure gauges.

## 9. START-UP AND RUNNING PROCEDURES

### 9a. Start-up checks

Before starting the pump, be sure that the following conditions have been met:

- Inlet line must be connected, and tight: **the pump must never run dry.**
- All ON-OFF valves in between the pump and water supply must be open. Be sure water flows into the pump.
- Be sure all connections are tight.
- Set the discharge line into the dump mode, to prime the pump.
- Be sure joint alignment, belt tension or U-joint angle are within Manufacturer's specification.
- Check oil level.

**NOTE:** If pump has not been operated for a long period of time, check the inlet and discharge lines for scaling.

### 9b. Start-up and operation

- Make sure the correct inlet pressure is provided.
- Do not start pump and motor (or engine) under load. Set the regulating valve to zero or set the discharge line into the dump mode.
- Check for proper direction of pump rotation.
- Be sure the rotating speed does not exceed the rated speed.
- Before putting the pump under pressure, let the pump run for some time until the oil flows freely.
- Before stopping the pump, relieve the pressure from the system.

### 9c. Cooling system

During operation a small amount of water (a few drops a minute) is released from the pump fluid end. This leakage is designed to provide lubrication for the pressure packings. The leakage is drained out of the pump through a hole in the cover (position 1). **Always leave this hole open.**

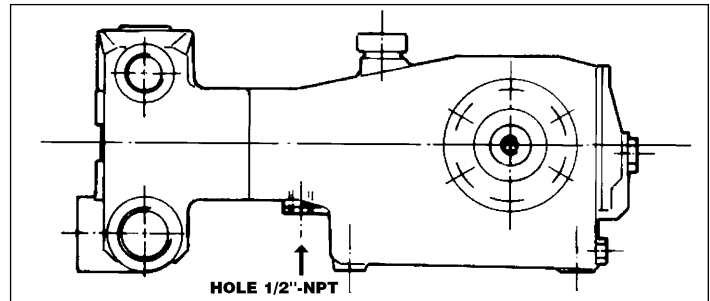

## 10. MAINTENANCE INSTRUCTIONS

### 10a. Crank mechanism maintenance

Check the oil level (position 9 or 12)\* frequently. It should be checked on a weekly basis. Stop the pump and provide immediate service if water gets into the oil. Before filling the pump with new oil, wash the crankcase and crank mechanism with a solvent and allow to dry completely. Oil seals (position 32) should be replaced every three years.

Change oil after 50 working hours and every 500 working hours thereafter.

**The oil must be changed at least once a year.**

We recommend you use General Pump oil or its equivalent. (If working at normal room temperature – from 32° to 113° F – use General Pump Series 220 Oil (P/N 100217).)

Pump oil pump capacity is 120 oz. (3.54 liters).

During oil changes, the pump oil should be at working temperature; be sure to clean the magnetic plug (position 11) and check the cover (position 1) for grease sediment.

\*All positions are referenced as shown on the parts breakdowns on pages 14 and 16.

### 10b. Fluid end maintenance

The fluid end **does not** require periodic maintenance.

Service operations are limited to valve inspection and/or replacement, when necessary:

- Step 1. Loosen the four valve cover screws (Ref. A) and gradually tighten the set screws to lift the valve unit and allow extraction by hand.

**IMPORTANT NOTE:** BEFORE REPOSITIONING THE VALVE UNITS, CLEAN AND DRY ALL VALVE HOUSINGS INSIDE THE MANIFOLD.

- Step 2. Replace each valve assembly. Before repositioning the valve assemblies in the fluid end, unscrew the set screws until they reach their initial position.
- Step 3. Replace all valve and valve cover O-rings at every inspection.
- Step 4. Replace valve cover screws (Ref. A) and tighten the screws to 90 ft.-lbs. in an alternating sequence.

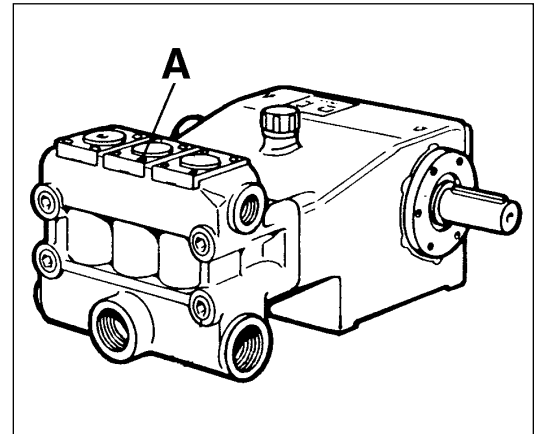

If excessive scaling inside the fluid end prevents valve extraction, open one of the three inlet ports, loosen the three plugs (Ref. B), and push the valve unit out as shown.

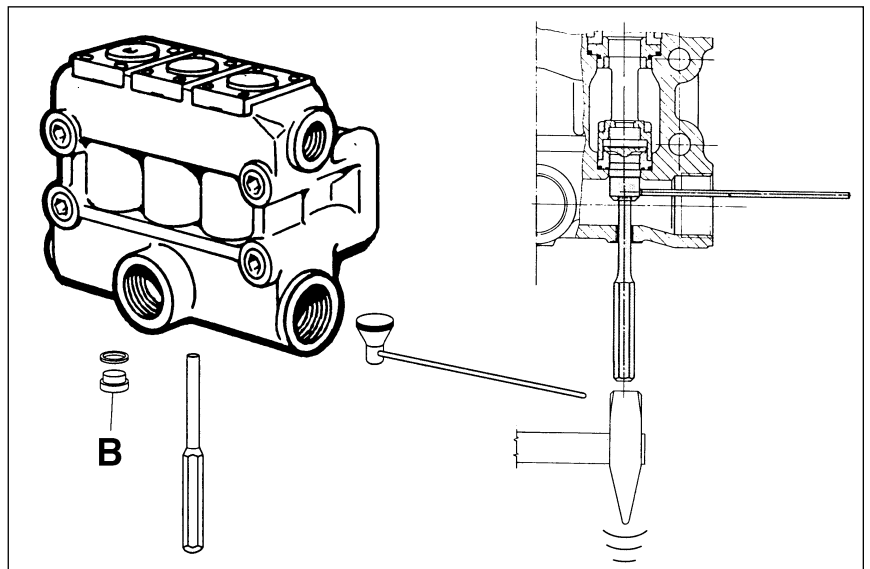

Periodically check the amount of water drained out by the pump through the hole provided in the cover. It clearly shows the pressure packing state of wear; replace packings if water dripping becomes continuous.

### Inspection/replacement of the pumping unit components:

- Step 1. Remove the manifold (position 53) by loosening the four mounting screws (position 54).
- Step 2. Remove the plunger bolt and washer (positions 29 and 28) and push the plunger forward.
- Step 3. Remove the packing support (position 34) and the plunger (position 27) .
- Step 4. Remove pressure packings (position 36) from manifold.
- Step 5. Replace all O-rings of the pumping unit.
- Step 6. When replacing the pressure packings, apply a very small quantity of silicone grease on their lips to ease assembly.
- Step 7. Set up the complete pumping unit and install it in the pump in one single block.
- Step 8. Tighten the plunger screws (position 29) to 50 ft.-lbs. The washer (position 28) (or the O-ring for KLZ-N-A versions) **should always be replaced.**
- Step 9. Install the manifold and tighten the screws (position 54) to 134 ft.-lbs. in an alternating sequence as shown.

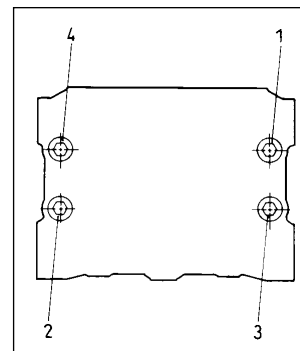

(position 54)

### 10d. Fastener torque values

Always use a torque wrench:

POSITION*	DESCRIPTION	Kgm	Nm	Ft-lbs
39	Valve cover screws	2.8	28	20
54	Manifold screws	18.5	182	134
29	Plunger screws	7	69	50
19	Connecting rod screws	4	39	29

\*All positions are referenced as shown on the parts breakdowns on pages 14 and 16.

## 11. PUMP STOPPED FOR LONG PERIOD

Before starting the pump after a long period of inactivity: (1) check for correct oil level, (2) check the valves as indicated in section 10b and (3) use the starting procedures indicated in section 9.

When a long period of inactivity is scheduled, drain the entire suction and delivery line and run the pump for a few seconds to drain out all water.

## 12. FROST PRECAUTIONS

When there is risk of freezing:

- Drain all suction and delivery lines (filter included).
- Run the pump for a few seconds to drain the water collected inside the manifold. Flush the system with a 50-percent solution of anti-freeze until the anti-freeze works throughout the system.

---

**WARNING:** If a pump is frozen or appears frozen **DO NOT OPERATE THE PUMP** until the entire system has been thawed.

---

## 13. KLZ-KLN-KLA Models

Installation, use and maintenance instructions for these models are the same as the standard ones. For the KLN versions, rinse with pure water after use.

### Torque values for KLZ-KLN-KLA models

Tighten screws using a torque wrench.

POSITION*	DESCRIPTION	Kgm	Nm	Ft-lbs
39	Valve cover screws	2.8	28	21
54	Manifold screws	18.5	181	133
29	Plunger screws	6	59	43
19	Connecting rod screws	4	39	29

\*All positions are referenced as shown on the parts breakdowns on pages 14 and 16.

10e. Parts breakdown

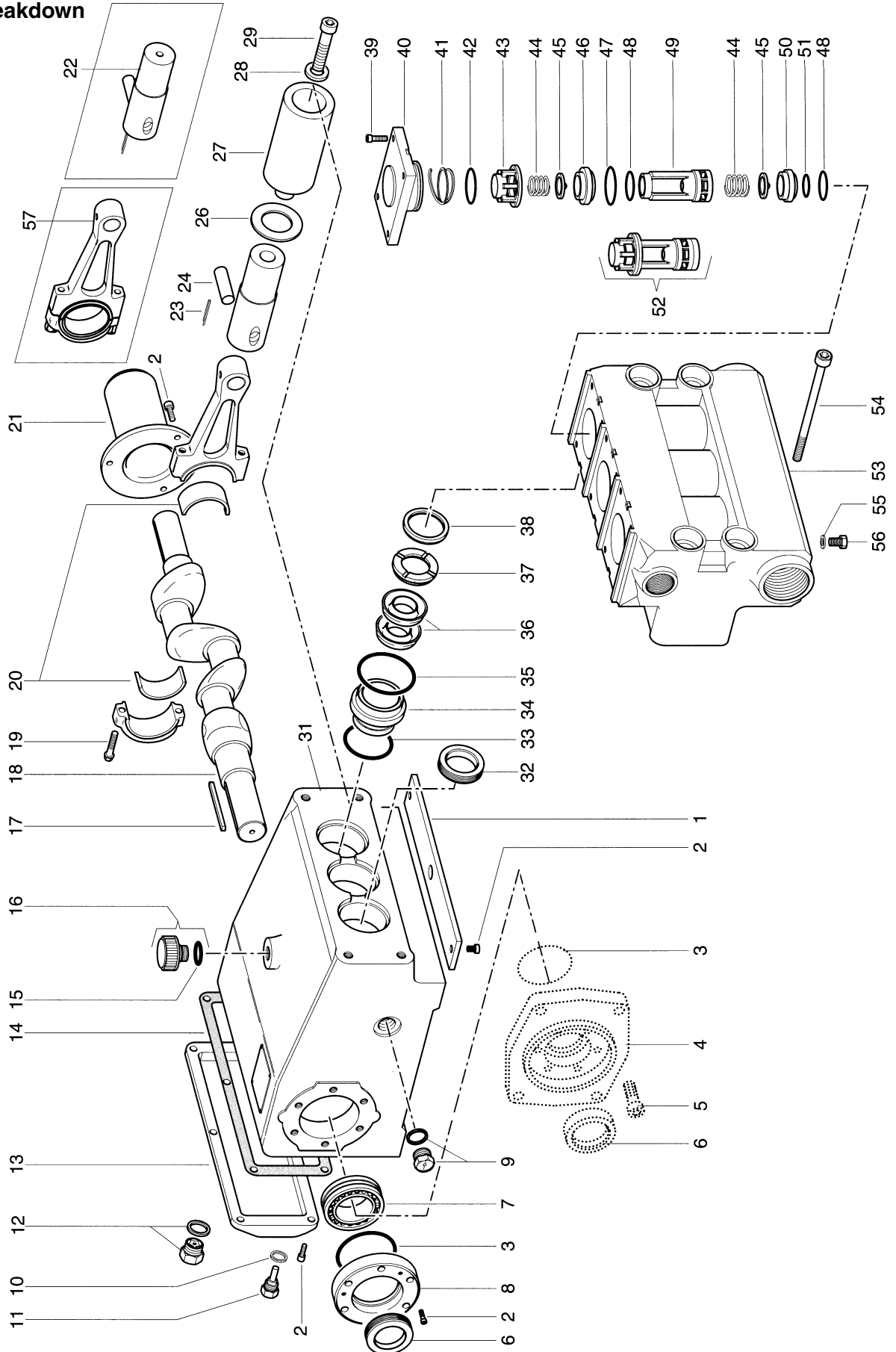

### KL SERIES PARTS

Pos. Code	Description	Kit Qty.	Pos. Code	Description	Kit Qty.	Pos. Code	Description	Kit Qty.
1	F040000130 Collector Plate	1	28	F872040003 Washer 12 - Special	A-C	38	F031300000 *Spring Loaded Spacer KL 30	3
2	F871115153 Screw M6 x 16	17-23	29	F871131518 Hex Socket Screw	3		F031300010 *Spring Loaded Spacer KL 33	3
3	F881013100 O-Ring 80 x 2.5	C		M12 x 110 KL 30-33-36-40			F031300020 Spring Loaded Spacer KL 36-40	3
4	F010100050 *Hydraulic Motor Flange, Type A	1		F871131509 Hex Socket Screw	3		F031300030 Spring Loaded Spacer KL 45-50	3
5	F010100040 *Hydraulic Motor Flange, Type B	1		M12 x 60 KL 45-50			F871121954 Valve Cover Bolt M8 x 25	12
6	F871125154 *Screw M10 x 30	6	31	F060100120 *Pump Body	1		F063300020 Closed Valve Cover	2
7	F881080014 Crankcase Oil Seal, 40 x 60 x 10	C		F060100130 *Hydraulic Pump Body	1		F063300010 Valve Cover G 1/4"	1
8	F811110002 Roller Bearing	2	32	F881081002 Piston Oil Seal 38 x 52 x 7	C		F881112001 Anti-Extrusion O-Ring	B-C
9	F801053002 Oil Level Indicator G 1/2"	1-2	33	F881010012 O-Ring 50.52 x 1.78	A-C		F881010214 O-Ring 49.21 x 3.53	B-C
10	F872043001 Aluminum Ring 3/8"	C	34	F022300090 *Gasket Holder KL 30	3		F021300010 Expanded Valve Guide	3
11	F801057001 Magnetic Cap G 3/8"	1		F022300110 *Gasket Holder KL 33	3		F090200020 Valve Spring	6
12	F801053003 Oil Leven Indicator G 3/4"	1		F022300120 *Gasket Holder KL 36	3		F082200020 Valve Plate	6
13	F063400120 Back Cover	1		F022300130 *Gasket Holder KL 40	3		F081200030 Delivery Valve Seat	3
14	F080600000 Back Gasket	C		F022300140 *Gasket Holder KL 45	3		F881011160 O-Ring 50.50 x 3	B-C
15	F881011173 O-Ring 18 x 3	C	35	F881010011 O-Ring 47.34 x 1.78 - KL 30	A-C		F881011157 O-Ring 36 x 3	B-C
16	F801054002 Pump Oil Cap G 1/2"	1		F881010012 O-Ring 50.52 x 1.78	A-C		F0213000370 Suction Valve Guide	3
17	F071000030 Crankshaft Key	1		KL 33-36-40			F021300320 Suction Valve Guide	3
18	F050000030 Crankshaft, 40 MM	1		F881010013 O-Ring 56.87 x 1.78	A-C		& Spacer KL 36-40-45-50	
19	F871350002 Connecting Rod Screw	6	36	F881020008 Pressure Gasket KL 30	A-C		F081200020 Suction Valve Seat	3
20	F812000002 Connecting Rod Bushing	3		F881020009 Pressure Gasket KL 33	A-C		F881010010 O-Ring 25.12 x 1.78	B-C
21	F040400010 Crankshaft Cover	1		F881020010 Pressure Gasket KL 36	A-C		F208004660 Valve Assembly KL 30-33	3
22	F250001020 Complete Piston	3		F881020011 Pressure Gasket KL 40	A-C		F208004670 Valve Assembly KL 36-40-45-503	3
23	F872138010 Elastic Pin 2.5 x 2.2	C		F881020012 Pressure Gasket KL 45	A-C		F064100110 Manifold KL 30	1
24	F071000020 Piston, 20	3		F881020013 Pressure Gasket KL 50	A-C		F064100130 Manifold KL 33	1
26	F041200000 Flinger	3		F031200070 *Gasket Seal Ring KL 30	A-C		F064100140 Manifold KL 36-40	1
27	F024200090 Ceramic Plunger KL 30	3	37	F031200080 *Gasket Seal Ring KL 33	3		F064100170 Manifold KL 45-50	1
	F024200100 Ceramic Plunger KL 33	3		F031200090 *Gasket Seal Ring KL 36	3		F871141119 Hex Socket Screw M16 x 150	4
	F024200110 Ceramic Plunger KL 36	3		F031200100 *Gasket Seal Ring KL 40	3		F872043000 Aluminum Washer 1/4"	B-C
	F024200120 Ceramic Plunger KL 40	3		F031200110 *Gasket Seal Ring KL 45	3		F084390000 Brass Cap G 1/4"	3
	F024200130 Ceramic Plunger KL 45	3		F881025002 *Anti-Extrusion Gasket Seal KL 50	3		F250000050 Complete Connecting Rod	3
	F024200140 Ceramic Plunger KL 50	3						

### REPAIR KITS

GROUP	ITEM	KL 30	KL 33	KL 36	KL 40	KL 45	KL 50
A	28-33-35-36	F1052	F1053	F1054	F1055	F1056	F1057
B	41-42-47-48-51-55	KIT 1058					
C	3-6-10-14-15-23-28 32-33-35 36-41-42-47-48-51	F1059	F1060	F1061	F1062	F1063	F1064
	55						

### TORQUE SPECS

Position	Ft./lbs.
29	50
54	134
19	29

## 10e. Parts breakdown

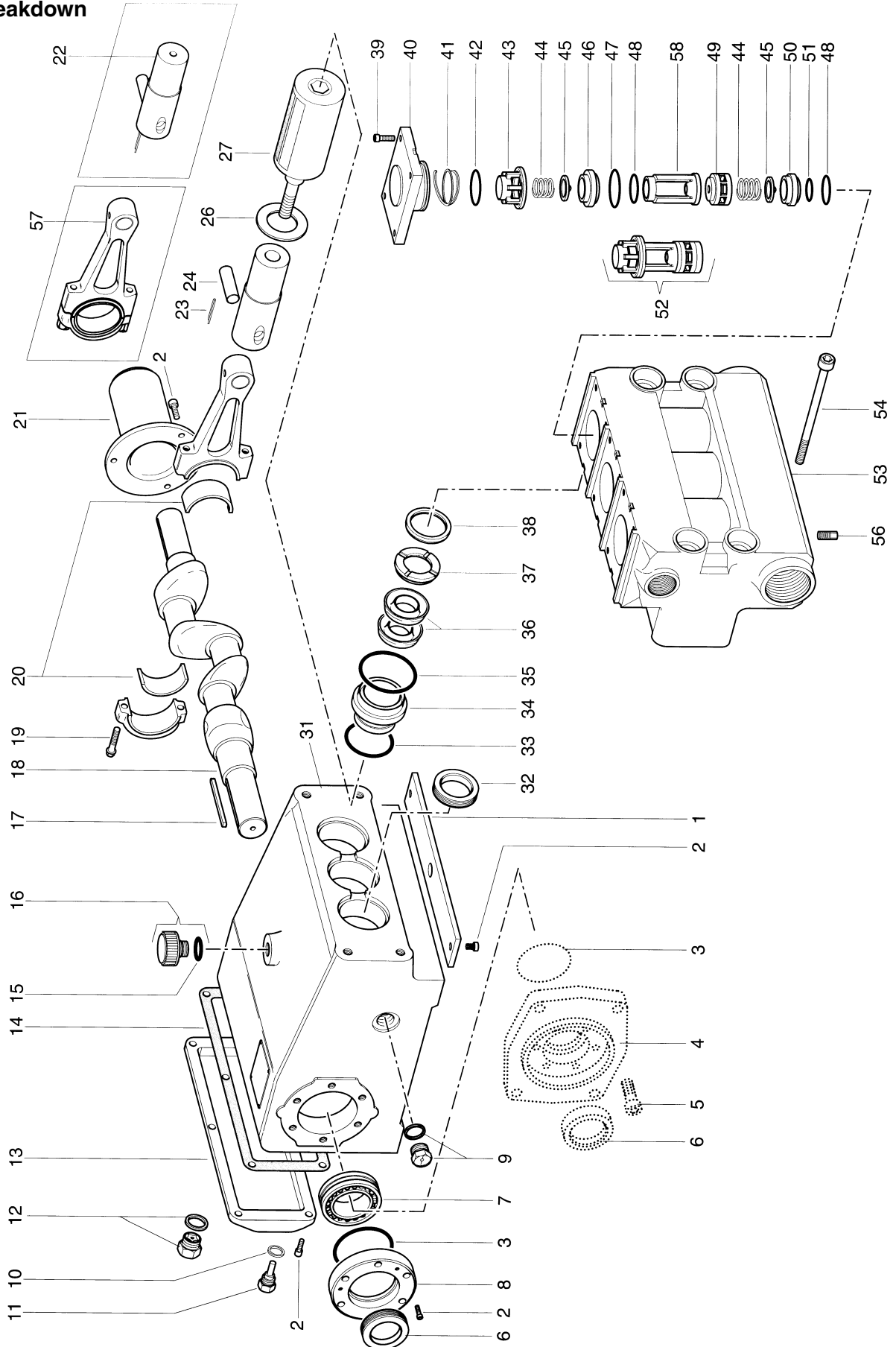



# MAINTENANCE LOG

## HOURS & DATE

<b>Oil Change</b>							
<b>Grease</b>							
<b>Packing Replacement</b>							
<b>Plunger Replacement</b>							
<b>Valve Replacement</b>							



**GP Companies, Inc.**

1174 Northland Drive  
Mendota Heights, Minnesota 55120  
(651) 454-6500 • Fax: (651) 454-4524