

FEATURES

- Features patent-pending “high tech” packings:
 - dynamic low-pressure seal retainer
 - superior low-pressure seal
 - innovative intermediate ring
 - superior high-pressure seal
- Ceramic plungers
- Patent-pending inlet/outlet valve cage
- Nickel-plated inlet/outlet valve plugs
- Nickel-plated forged brass manifold with an exclusive lifetime warranty
- Specifically designed to handle rigorous duty cycles, high temperatures and chemicals
- Ideal for use in carpet cleaning and other high pressure cleaning applications

Emperor

Pumps That Rule Any Environment



SPECIFICATIONS

Pump Model	HTX1810S	HTX1812S	HTX1813S
Maximum Volume	2.7/3.1 GPM	3.2/3.8 GPM	3.5 GPM
Maximum Pressure	2000 PSI		2500 PSI
Maximum RPM	1450/1750 RPM		1450 RPM
Maximum Inlet Pressure	125 PSI		
Minimum Inlet Pressure	3 ft. water (2.6 in. Hg)		
Maximum Fluid Temperature	185°F		
Bore (in / mm)	.709 in. / 18 mm		
Stroke (in / mm)	.394 in. / 10 mm	.472 in. / 12 mm	.512 in. / 13 mm
Oil Capacity	14.0 oz.		
Inlet Port Thread	1/2"-14 BSP-F		
Discharge Port Thread	3/8"-19 BSP-F		
Shaft Diameter	.945 in. / 24 mm		
Weight	18 lbs.		
Dimensions - Nominal	8.4" x 8.3" x 5.6"		

Instructions and Recommendations for the Installation of *HT Series Pumps*

The high-temperature pumps of the HT series have been designed for use in applications where the water must be pre-heated, such as in carwash, food and pharmaceutical industries.

Maximum temperature of the water through the pump is 185°F (85°C).

In order to obtain maximum performance in terms of duration of seals and valves, it is necessary to respect a few simple rules, as follows:

1) **In order to avoid damage caused by cavitation, the pump must be pressure fed.**

The higher the inlet pressure, the longer the life of the wet end of the pump.

When working at 185°F (85°C), the minimum feed pressure - measured directly in the inlet port of the pump when it is working - is 45 psi (3 bar).

The minimum feed pressure according to the different temperatures are:

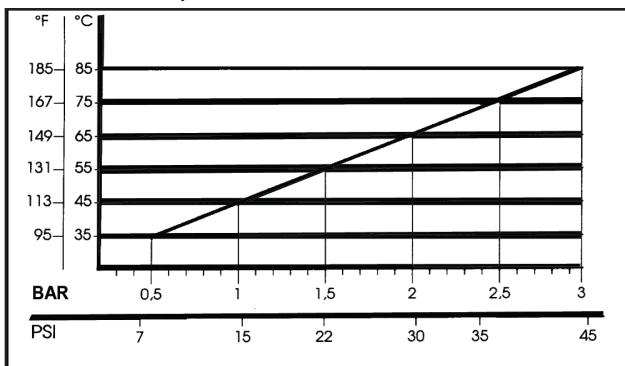

Naturally, if the application allows for feeding the pump with 45 psi (3 bar) even at low temperatures (for example: 115°F/45°C the life of the wet end of the pump will be even longer.

2) **The plumbing which feeds the pump must be of a diameter at least equal to the inlet port.**

Also, follow the suggestions below:

a) Make the plumbing as short and straight as possible, preferably in an upward direction to facilitate the expulsion of eventual air bubbles naturally if compatible with the requirements of the system.

b) It is always useful to put a filter at the inlet with capacity of 4 to 5 times the flow of

the pump, for example for a 4 gpm (15 l/min) pump, put a filter from 16 to 20 gpm (60-75 l/min). The mesh size suitable for this application is 0.016" (.4 mm).

c) It is extremely important to put a pressure switch on the suction port of the pump, and in any case downstream from the filter, so that it can stop the pump should the feed pressure drop by 20% due to the filter clogging or failure of the feed pump, etc.

3) **Change of oil**

We recommend the **first oil change after the first 50 hours**, with the **pump stopped** and the **oil still warm**.

This change is not recommended because the oil has lost its properties, but rather to eliminate the impurities that have gotten into the oil during the running-in phase. If these impurities are not removed, but are allowed to remain in the oil, they *may cause premature wear* to the moving parts and the oil seals. **After this initial change, the oil can then be changed every three months or 300 hours of operation thereafter.**

Please note: If the pump works in conditions with high humidity and with sharp temperature changes, it is possible that condensation will appear inside the crankcase, which mixing with the oil can change its properties. This is easy to see because the oil changes to a white, milky color.

If the pump does not have excessive water leaking from the packings, and the oil becomes milky, the oil has to be changed more frequently. The percentage of water in the oil must not exceed 20%.

Use oil per the following chart:

CHART OF COMPATIBLE OILS SAE15W40	
GENERAL PUMP	SERIES 100
BP	VISCO 2000
CASTROL	CWX
MOBIL	SUPER
SHELL	HELIX SUPER
TOTAL	QUARTZ 4000-5000

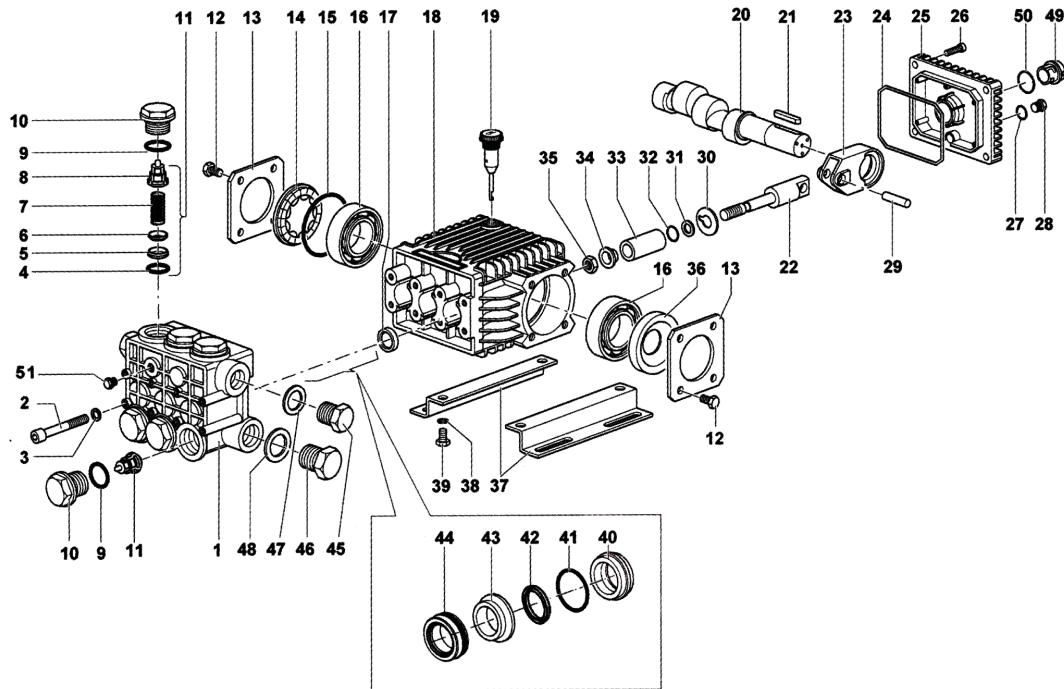

PARTS LIST

ITEM	PART NO.	DESCRIPTION	QTY	ITEM	PART NO.	DESCRIPTION	QTY	ITEM	PART NO.	DESCRIPTION	QTY
1.	63121341	Manifold, Nickel Plated 18mm	1	19.	98210300	Dipstick, Vented	1	35.	92221600	Nut, M8, S.S.	3
2.	99319200	Head Bolt, M8	8	20.	63021265	Crankshaft, HTX1810S	1	36.	90164100	Crankshaft Oil Seal	1
3.	96701400	Washer, M8	8		63021665	Crankshaft, HTX1812S		37.	50200074	Pump Rail	2
4.	90384100	O-ring	6		63021865	Crankshaft, HTX1813S		38.	96701600	Washer, M8.4	4
5.	36200366	Valve Seat	6	21.	91489200	Key	1	39.	99303700	Screw, M8	4
6.	36200176	Valve Poppet	6	22.	63050066	Plunger Guide	3	40.	63080370	Seal Retainer, 18mm	3
7.	94737600	Valve Spring	6	23.	63030022	Connecting Rod	3	41.	90360800	O-ring	3
8.	36202551	Valve Guide	6	24.	90392000	O-ring	1	42.	90220000	L.P. Seal, 18mm	3
9.	90384700	O-ring	6	25.	63160022	Crankcase Cover	1	43.	63216170	Intermediate Ring, 18mm	3
10.	98222500	Valve Cap, Nickel-plated	6	26.	99183700	Screw, M6	4	44.	90221000	H.P. Seal, 18mm	3
11.	36711501	Valve, Complete	6	27.	90358500	O-ring	1	45.	98209900	Plug, G3/8", Nickel-plated	1
12.	99180700	Screw, M8	8	28.	98204100	Plug, 1/4"	1	46.	98217900	Plug, G1/2", Nickel-plated	1
13.	50150074	Side Cover	2	29.	97733500	Wrist Pin	3	47.	96738000	Washer, M17.5	1
14.	44211801	Oil Level Indicator	1	30.	96707500	Flinger Washer	3	48.	96751400	Washer, M21.5	1
15.	90409700	O-ring	1	31.	90502200	Anti-Extrusion Ring	3	49.	63210051	Oil Level Indicator	1
16.	91833100	Bearing, Ball	2	32.	90357300	O-ring	3	50.	90405100	O-ring	1
17.	90159500	Plunger Rod Oil Seal	3	33.	44040109	Plunger, 18mm	3	51.	98204200	Plug, G1/4", Nickel-plated	1
18.	63010022	Crankcase	1	34.	44211570	Collared Washer	3				

REPAIR KITS

KIT NO.	K123	K158	K159	K204	K205
ITEM NO'S INCLUDED IN KIT	4, 5, 6, 7, 8 (11)	9, 10	17	42, 44	40, 41, 42, 43, 44
NUMBER OF ASSY'S IN KIT	6	6	3	3	1
NO. OF CYLINDERS KIT SERVICES	3	3	3	3	1

TORQUE SPECS*

Position	Ft.-Lbs.	Nm.
2	14.7	20
10	95.9	130
12	7.3	10
26	7.3	10
28	14.7	20
35**	11.0	15
39	14.7	20
45	29.4	40
46	29.4	40
51	14.7	20

*Decrease torque by 20% if threads are lubricated.

**Use Loctite 542.

DIMENSIONS

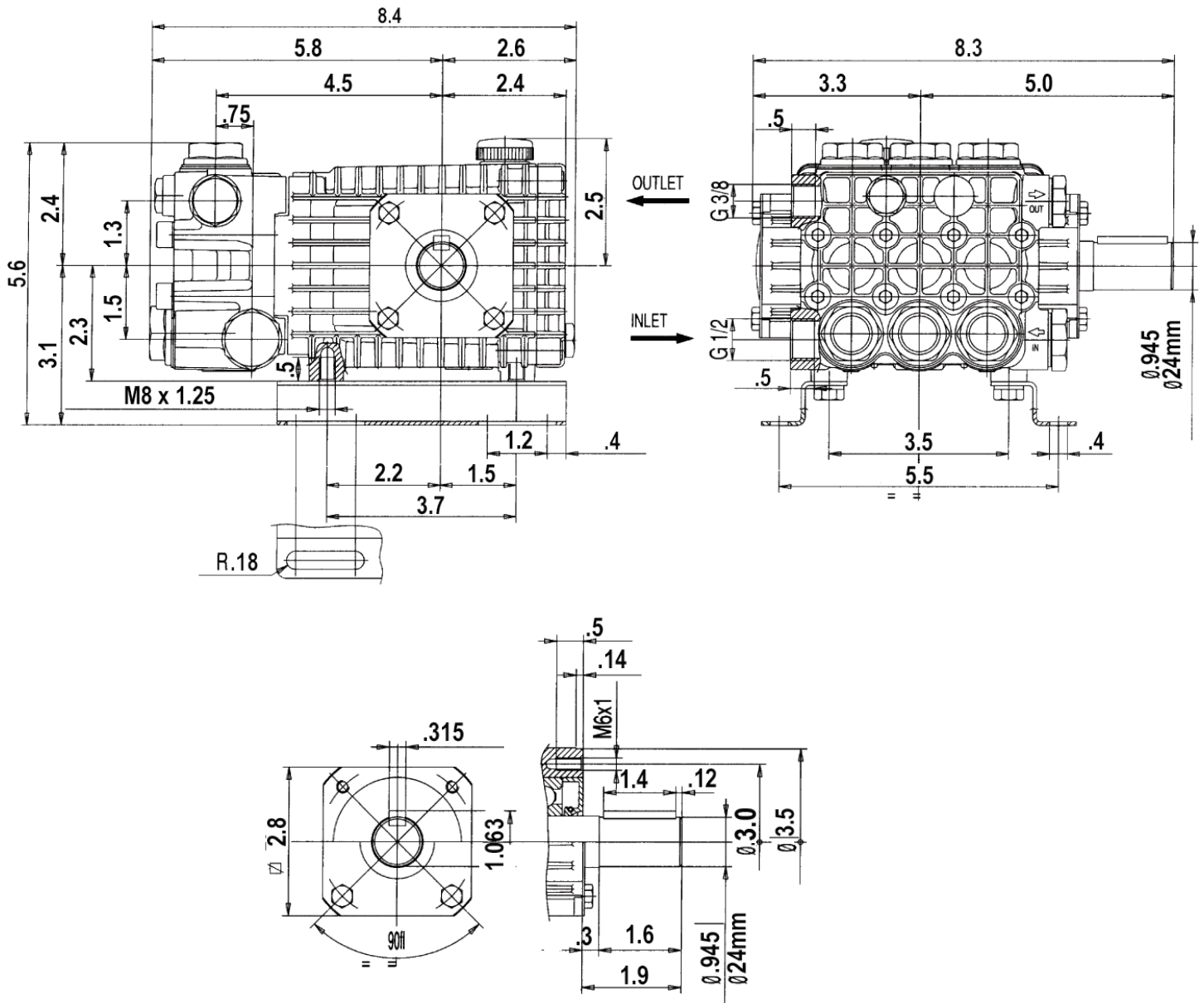

Ref 300546 Rev.A
05-05