

Car Wash Series – Triplex Plunger Pump

FEATURES

- The preferred pump frame in the car wash self-service industry
- Dual crankshaft for convenience
- Forged brass manifold with an exclusive lifetime warranty
- Large-capacity, die-cast, anodized aluminum oil-bath crankcase
- Over-sized connecting rods for maximum life
- Heavy-duty tapered roller bearing.
- Solid ceramic plungers with continuously lubricated packings
- Unitized stainless steel inlet and discharge valves



SPECIFICATIONS

Pump Model	CW2040
Maximum Volume	5.0 GPM @ 1500 PSI, 1250 RPM
Max. Discharge Pressure	2500 PSI @ 3.0 GPM, 750 RPM
Maximum Pump Speed	1250 RPM @ 5.0 GPM, 2000 PSI
Maximum Inlet Pressure	125 PSI
Bore	.787 in. / 20 mm
Stroke	.630 in. / 16 mm
Crankcase Oil Capacity	33.8 oz.
Maximum Fluid Temp.	165°F
Inlet Port Thread	1/2-14 BSPP-F
Discharge Port Thread	3/8-19 BSPP-F
Shaft Diameter.	.945 in. / 24 mm Dual Shaft
Weight	30 lbs.
Dimensions	11.4 x 10.8 x 7.2 in.

DIMENSIONAL DRAWING

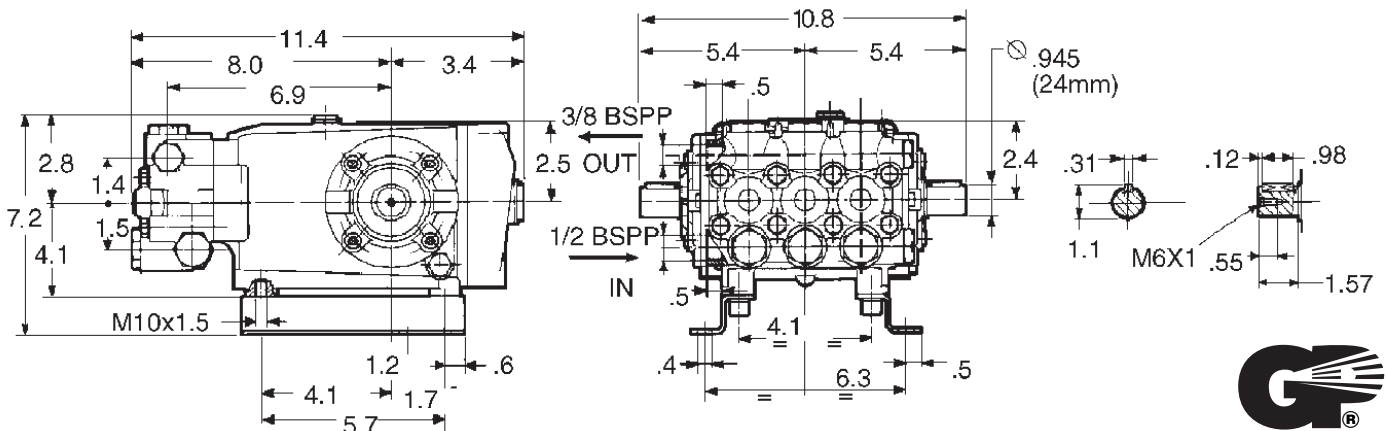

CW2040

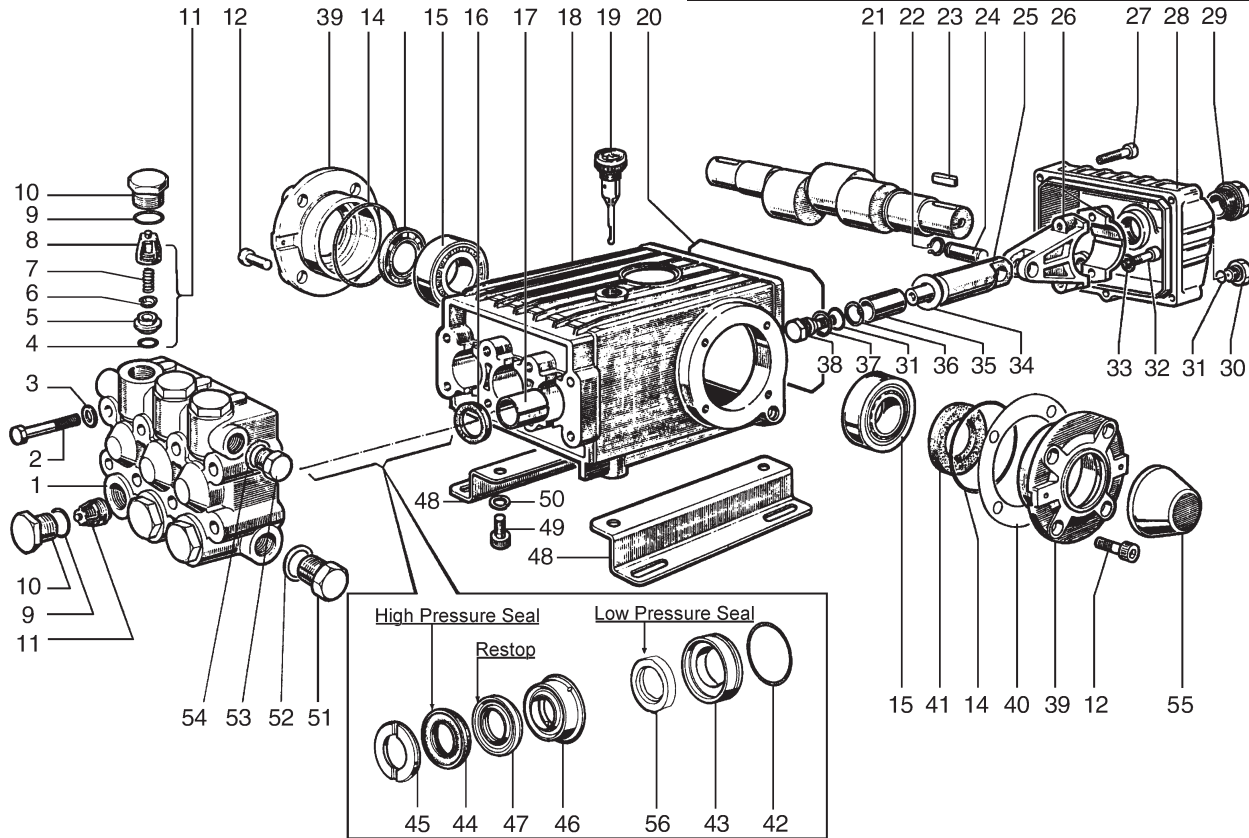

PARTS LIST

ITEM PART NO.	DESCRIPTION	KIT NO.	QTY.	ITEM PART NO.	DESCRIPTION	KIT NO.	QTY.	ITEM PART NO.	DESCRIPTION	KIT NO.	QTY.
1. 47120841	Manifold		1	21. 47021635	Crankshaft - dual		1	41. 90164800	Seal, Oil		2
2. 99320600	Screw, M8 x 70		8	22. 90055700	Ring, Snap, M12		6	42. 90361600	O-Ring, 1.364 x .070		3
3. 96702000	Washer, M8.4		8	23. 91489000	Key		1	43. 47080970	Retainer, Seal, Low Press.		3
4. 90384100	O-Ring, .674 x .103		6	24. 97738000	Pin, Wrist		3	44. 90270500	Seal, High Pressure		3
5. 36200366	Seat, Valve		6	25. 47050454	Guide, Piston		3	45. 47100051	Ring, Head, M20		3
6. 36200176	Plate, Valve		6	26. 47030001	Rod, Connecting		3	46. 47216970	Ring, Intermed., M20		3
7. 94737600	Spring		6	27. 99183700	Screw, M6 x 14		5	47. 90270400	Ring, Restop		3
8. 36200251	Guide, Valve		6	28. 47160322	Cover, Crankcase		1	48. 47200074	Rail, Pump		2
9. 90384700	O-Ring, .797 x .103		6	29. 97596800	Oil Indicator		1	49. 99364400	Screw, M10 x 18		4
10. 98222000	Cap, M24		6	30. 98204100	Cap		1	50. 96710600	Washer, M10.2		4
11. 36703201	Valve Assembly		6	31. 90358500	O-Ring, .426 x .070		4	51. 98217600	Cap		1
12. 99303900	Screw, M8 x 16		8	32. 99309900	Screw, M8 x 35		6	52. 96751400	Washer, M21.5		1
14. 90391300	O-Ring, 2.68 x .103		2	33. 96701400	Washer, M8.4		6	53. 98210000	Cap		1
15. 91837500	Bearing, Roller		2	34. 96728600	Washer, M14		3	54. 96738000	Washer, M17.5		1
16. 90162500	Seal, Oil		3	35. 47040409	Plunger, (20 mm)		3	55. 47212351	Shaft Cover, Red		1
17. 90912600	Bushing		3	36. 90506700	Ring, Back-up		3	56. 90269400	Seal, Low Pressure		3
18. 47010422	Crankcase		1	37. 96728000	Washer, M14		3				
19. 98210600	Oil Dip Stick		1	38. 47219566	Screw, Plunger		3				
20. 47211984	Cover, Gasket		1	39. 47150022	Cover, Crankcase		2				
				40. 97567800	Shim		2				
								Optional			
								190160	Rail & Coupler Kit (310)		1
								190161	Rail & Coupler Kit (530)		1

REPAIR KITS

KIT NO.	K01	K02	K03	K04	K06	K07	K71	K969	K9101A	K910
ITEM NO.s INCLUDED IN KIT	11	16	41	9, 10	31, 34, 36, 37, 38	45	46, 47	44, 47, 56	42, 43, 44, 45, 46, 47, 56	42, 43, 56
NUMBER OF ASSEMBLIES IN KIT	6	3	2	6	3	6	3	3	1	3
NUMBER OF CYLINDERS KIT WILL SERVICE	6	3	-	3	3	3	3	3	1	3

TORQUE SPECS*

Position	Ft.-lbs.
2	22.1
10	73.7
12	14.7
27	7.3
29	13.2
30	14.7
32	14.7
38	14.7
49	29.4
51	29.4

*Decrease torque by 20% if threads are lubricated.