

FWS VERSION - CUSCINETTI A SFERE / BALL BEARINGS - 1750 RPM

SOLO PER MODELLI / ONLY FOR MODELS **3522 E - 4020 E**

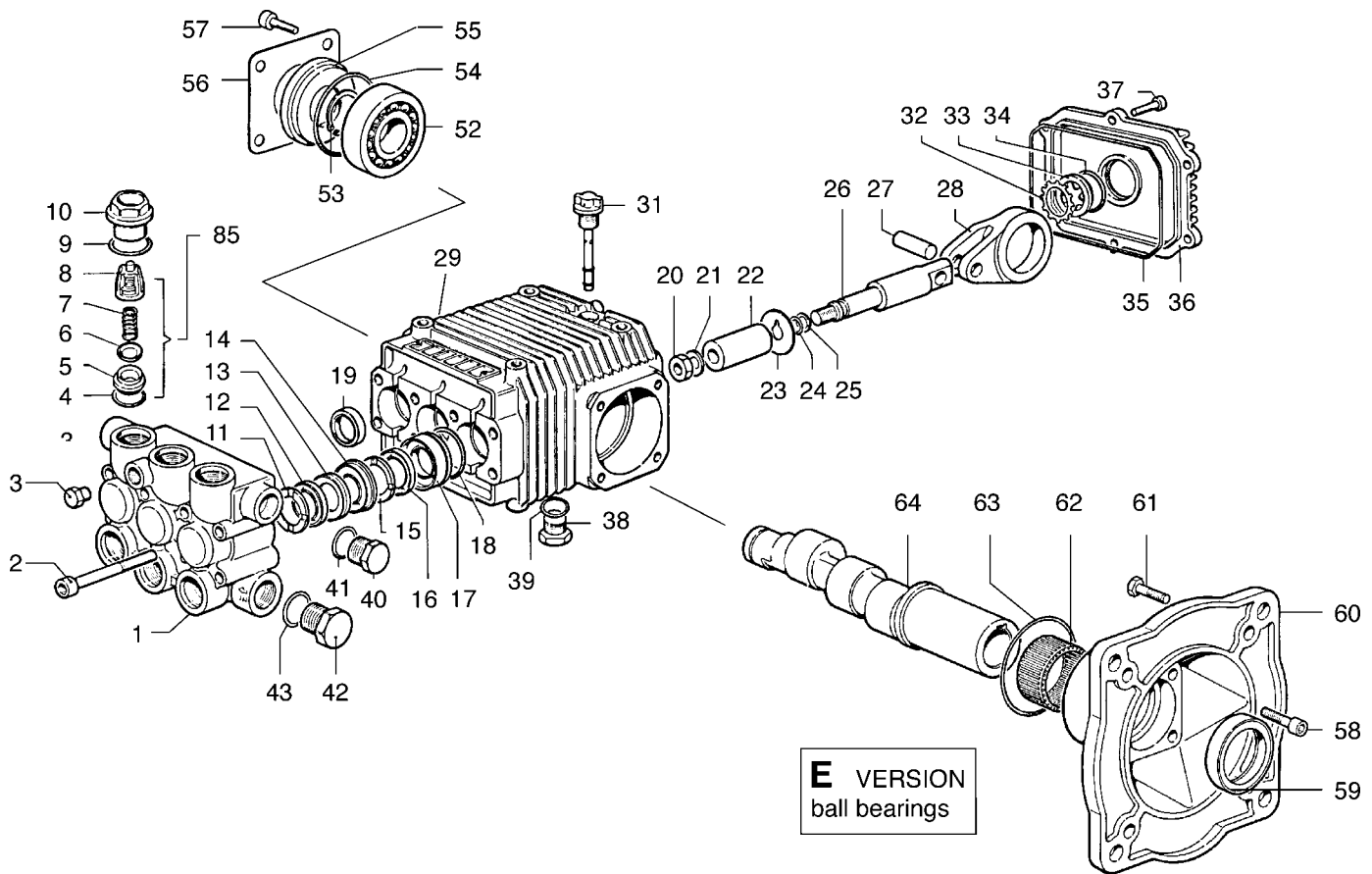

POS. ITEM	CODICE PART No.	KIT KIT	DESCRIZIONE DESCRIPTION	Q.tà Qty.	MODELLI MODELS
1	3218.0110.00		MANIFOLD Ø 18 mm	1	
2	3609.0039.00		SCREW M8X70	8	
3	3202.0112.00		CAP G1/4	1	
4	1210.0046.00	A-D	O-RING 2,62X 17,13 mm	6	
5	3009.0087.00	A	VALVE SEAT	6	
6	3604.0017.00	A	VALVE PLATE	6	
7	1802.0177.00	A	SPRING	6	
8	1205.0025.00	A	VALVE CAGE	6	
9	1210.0048.00	A-D	O-RING 2,62X 20,24 mm	6	
10	3202.0155.00		CAP	6	
11	0009.0199.00	B	HEAD RING Ø18 mm	3	
12	1241.0026.00	B	PACKING Ø 18 mm	3	
13	0009.0100.00	B	PACKING Ø18 mm	3	
14	0009.0200.00		INTERMED. RING Ø18 mm	3	
15	0009.0199.00	B	HEAD RING Ø18 mm	3	
16	1241.0026.00	B	PACKING Ø18 mm	3	
17	0009.0102.00		PACKING RETAINER Ø18mm	3	
18	1210.0156.00	B-D	O-RING 1,78X31,47 mm	3	
19	0019.0066.00	D	OIL SEAL 20X30X5 mm	3	
20	0600.0054.00	C	NUT	3	
21	2811.0082.00	C	WASHER 8,2X17X1,5 mm	3	
22	0202.0022.00	C	BUSH Ø18 mm	3	
23	2812.0042.00	C	WASHER	3	
24	1210.0039.00	C-D	O-RING 1,78X 7,66 mm	3	
25	0009.0170.00	C-D	ANTI-EXTR. RING	3	
26	2409.0048.00		PISTON GUIDES	3	
27	3011.0016.00		WRIST. PIN Ø10X29 mm	3	
28	0205.0046.00		CON. ROD	3	
29	0403.0130.00		CRANKCASE	1	

POS. ITEM	CODICE PART No.	KIT KIT	DESCRIZIONE DESCRIPTION	Q.tà Qty.	MODELLI MODELS
31	3200.0051.00		OIL DIPSTICK	1	
32	3019.0033.00		SNAP RING Ø18 mm	1	
33	3201.0012.00		OIL INDICATOR	1	
34	1210.0333.00	D	O-RING 1,78X23,52 mm	1	
35	1210.0216.00	D	O-RING 2,62X107,62 mm	1	
36	0402.0169.00		CRANKCASE COVER	1	
37	3609.0030.00		SCREW M5X20	6	
38	3200.0007.00		CAP 3/8 GAS	1	
39	1210.0441.00	D	O-RING 2X14 mm	1	
40	3200.0007.00		CAP 3/8 GAS	1	
41	2811.0084.00		WASHER 16,7X22X1,5 mm	1	
42	3202.0015.00		CAP G1/2	1	
43	2811.0086.00		WASHER 21,2X27X1,5 mm	1	
52	0438.0071.00		BALL BEARING 25X62X17mm	1	
53	3019.0006.00		SNAP RING C72	1	
54	1210.0387.00	D	O-RING 2,62X63,17 mm	1	
55	0402.0176.00		SPACER	1	
56	1004.0015.00		CRANKCASE COVER	1	
57	3609.0068.00		SCREW M6X12	4	
58	3609.0058.00		SCREW M8X22	4	
59	0019.0052.00	D	OIL SEAL 40X52X7 mm	1	
60	3016.0019.00		FLANGE	1	
61	3607.0201.00		SCREW 1/2" - 13	4	
62	0437.0027.00		NEEDLE 40X47X20 mm	1	
63	1210.0150.00	D	O-RING 3,53X55,56 mm	1	
64	0001.0356.00		CRANKSHAFT 1"1/8"	1	4022 E
	0001.0355.00		CRANKSHAFT 1"1/8"	1	3522 E
85	1220.0030.00		VALVE ASS. BLY.	6	

FWS VERSION - CUSCINETTI A SFERE / BALL BEARINGS - 1750 RPM

KIT VALVOLA ASP-MAND.
COMPLETE VALVE KIT
 5025.0011.00

KIT A

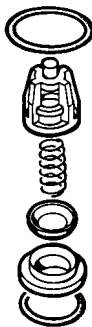

5025.0011.00

POS. ITEM	CODICE PART No.	Q.tà Qty.
4	1210.0046.00	6
5	3009.0087.00	6
6	3604.0017.00	6
7	1802.0177.00	6
8	1205.0025.00	6
9	1210.0048.00	6

KIT GUARNIZIONI PISTONE / PISTON SEAL KIT
 Ø 18 mm 5019.0038.00

KIT B

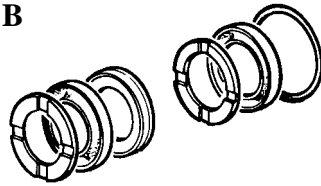

5019.0038.00

POS. ITEM	CODICE PART No.	Q.tà Qty.
11	0009.0199.00	3
12	1241.0026.00	3
13	0009.0100.00	3
15	0009.0199.00	3
16	1241.0026.00	3
18	1210.0156.00	3

KIT PISTONE / PISTON KIT
 Ø 18 mm 2409.0073.00

KIT C

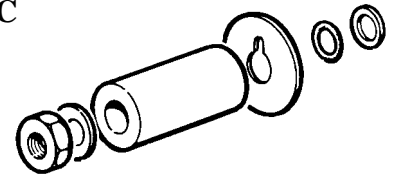

2409.0073.00

POS. ITEM	CODICE PART No.	Q.tà Qty.
20	0600.0054.00	3
21	2811.0082.00	3
22	0202.0022.00	3
23	2812.0042.00	3
24	1210.0039.00	3
25	0009.0170.00	3

KIT GUARNIZIONI POMPA / SEAL KIT
 ALBERO FEMMINA / HOLLOW SHAFT 5019.0043.00

KIT D

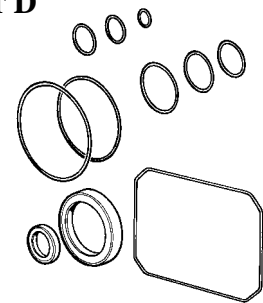

5019.0043.00

POS. ITEM	CODICE PART No.	Q.tà Qty.
4	1210.0046.00	6
9	1210.0048.00	6
18	1210.0156.00	3
19	0019.0066.00	3
24	1210.0039.00	3
25	0009.0170.00	3
34	1210.0333.00	1
35	1210.0216.00	1
39	1210.0441.00	1
54	1210.0387.00	1
59	0019.0052.00	1
63	1210.0150.00	1

FWS VERSION - CUSCINETTI A RULLI / *ROLLER BEARINGS* - 1750 RPM

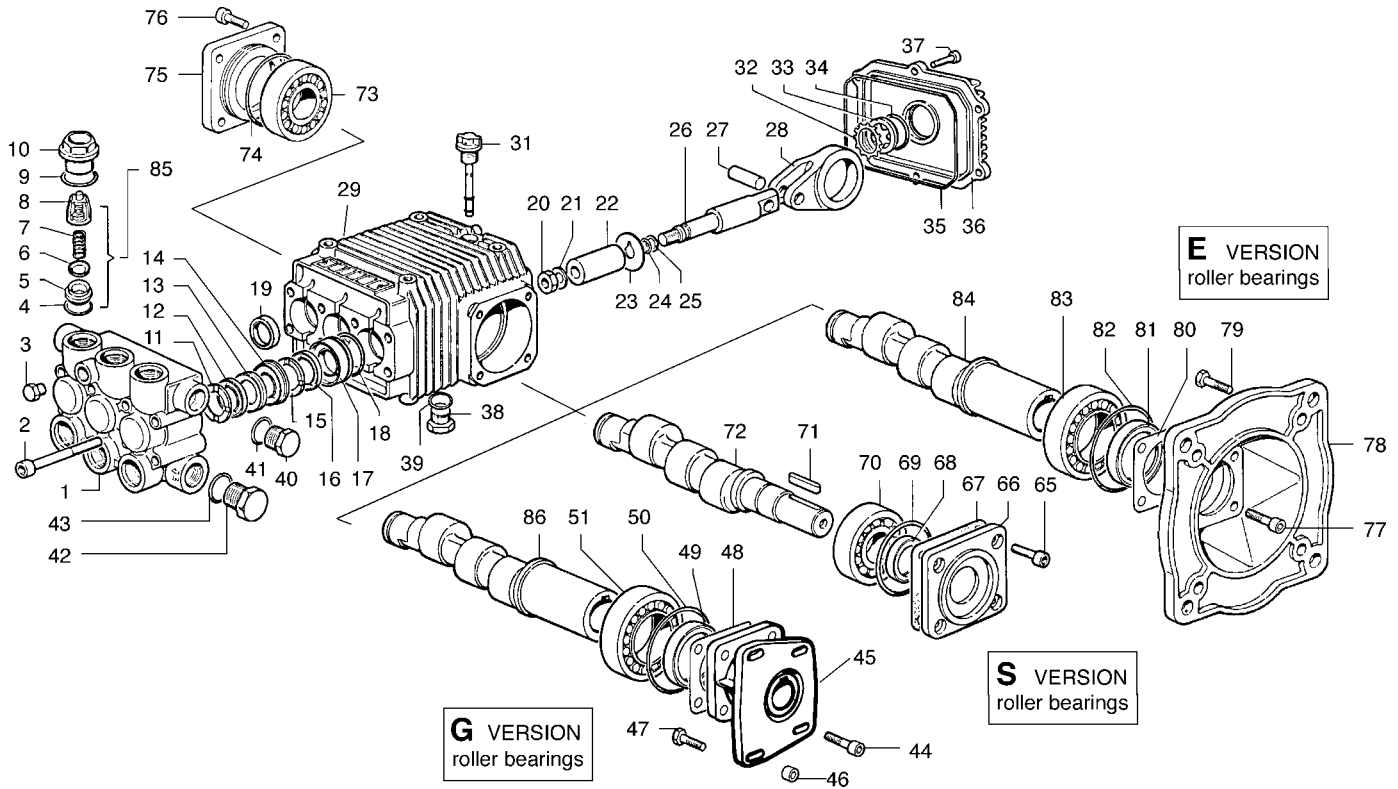

POS. ITEM	CODICE PART No.	KIT KIT	DESCRIZIONE DESCRIPTION	Q.tà Qty.	MODELLI MODELS
1	3218.0109.00		MANIFOLD Ø 20 mm	1	5520 S - 5525 S 6020 S - 5530 E
	3218.0110.00		MANIFOLD Ø 18 mm	1	3530 S - 3530 E 4030 S - 4030 E 4030 G - 4525 S 4530 S - 4530 E
2	3609.0039.00		SCREW M8X70	8	
3	3202.0112.00		CAP G1/4"	1	
4	1210.0046.00	A-D	O-RING 2,62X 17,13 mm	6	
5	3009.0087.00	A	VALVE SEAT	6	
6	3604.0017.00	A	VALVE PLATE	6	
7	1802.0177.00	A	SPRING	6	
8	1205.0025.00	A	VALVE CAGE	6	
9	1210.0048.00	A-D	O-RING 2,62X 20,24 mm	6	
10	3202.0155.00		CAP	6	
11	0009.0108.00	B	HEAD RING Ø20 mm	3	5520 S - 5525 S 6020 S - 5530 E
	0009.0199.00	B	HEAD RING Ø18 mm	3	3530 S - 3530 E 4030 S - 4030 E 4030 G - 4525 S 4530 S - 4530 E
12	1241.0032.00	B	PACKING Ø 20 mm	3	5520 S - 5525 S 6020 S - 5530 E
	1241.0026.00	B	PACKING Ø 18 mm	3	3530 S - 3530 E 4030 S - 4030 E 4030 G - 4525 S 4530 S - 4530 E
13	0009.0100.00	B	PACKING Ø18 mm	3	3530 S - 3530 E 4030 S - 4030 E 4030 G - 4525 S 4530 S - 4530 E
	0009.0104.00	B	PACKING Ø20 mm	3	5520 S - 5525 S 6020 S - 5530 E
14	0009.0114.00		INTERMED. RING Ø 20 mm	3	5520 S - 5525 S 6020 S - 5530 E
	0009.0200.00		INTERMED. RING Ø 18 mm	3	3530 S - 3530 E 4030 S - 4030 E 4030 G - 4525 S 4530 S - 4530 E
15	0009.0108.00	B	HEAD RING Ø 20 mm	3	5520 S - 5525 S 6020 S - 5530 E
	0009.0199.00	B	HEAD RING Ø 18 mm	3	3530 S - 3530 E 4030 S - 4030 E 4030 G - 4525 S 4530 S - 4530 E
16	1241.0032.00	B	PACKING Ø 20 mm	3	5520 S - 5525 S 6020 S - 5530 E
	1241.0026.00	B	PACKING Ø 18 mm	3	3530 S - 3530 E 4030 S - 4030 E 4030 G - 4525 S 4530 S - 4530 E

POS. ITEM	CODICE PART No.	KIT KIT	DESCRIZIONE DESCRIPTION	Q.tà Qty.	MODELLI MODELS
17	0009.0102.00		PACKING RETAINER Ø18 mm	3	3530 S - 3530 E 4030 S - 4030 E 4030 G - 4525 S 4530 S - 4530 E
	0009.0106.00		PACKING RETAINER Ø20 mm	3	5520 S - 5525 S 6020 S - 5530 E
18	1210.0156.00	B-D	O-RING 1,78X31,47 mm	3	
19	0019.0066.00	D	OIL SEAL 20X30X5 mm	3	
20	0600.0054.00	C	NUT	3	
21	2811.0082.00	C	WASHER 8,2X17X1,5 mm	3	
22	0202.0022.00	C	PISTON Ø18 mm	3	3530 S - 3530 E 4030 S - 4030 E 4030 G - 4525 S 4530 S - 4530 E
	0202.0024.00	C	PISTON Ø20 mm	3	5520 S - 5525 S 6020 S - 5530 E
23	2812.0042.00	C	WASHER	3	
24	1210.0039.00	C-D	O-RING 1,78X 7,66 mm	3	
25	0009.0170.00	C-D	ANTI-EXTR. RING	3	
26	2409.0048.00		PISTON GUIDES	3	
27	3011.0016.00		WRIST. PIN Ø10X29 mm	3	
28	0205.0044.00		CON. ROD	3	
29	0403.0129.00		CRANKCASE	1	3530 S - 4030 S 4525 S - 4530 S 5520 S - 5525 S 6020 S
	0403.0130.00		CRANKCASE	1	3530 E - 4030 E 4030 G - 4530 E 5530 E
31	3200.0051.00		OIL DIPSTICK	1	
32	3019.0033.00		SNAP RING Ø18 mm	1	
33	3201.0012.00		OIL INDICATOR	1	
34	1210.0333.00	D	O-RING 1,78X23,52 mm	1	
35	1210.0216.00	D	O-RING 2,62X107,62 mm	1	
36	0402.0169.00		CRANKCASE COVER	1	
37	3609.0030.00		SCREW M5X20	6	
38	3200.0007.00		CAP 3/8 GAS	1	
39	1210.0093.00	D	O-RING 1,78X 14 mm	1	
40	3200.0007.00		CAP 3/8 GAS	1	
41	2811.0084.00		WASHER 16,7X22X1,5 mm	1	
42	3202.0015.00		CAP G1/2	1	
43	2811.0086.00		WASHER 21,2X27X1,5 mm	1	
44	0440.0012.00		ROLLER BEARING	1	
45	1210.0388.00	D	O-RING	1	
46	0402.0171.00		FLANGE	1	
47	3609.0032.00		SCREW M6X20	4	
48	1220.0030.00		VALVE ASS. BLY.	6	

FWS VERSION - CUSCINETTI A RULLI / *ROLLER BEARINGS* - 1750 RPM

S version

POS. ITEM	CODICE PART No.	KIT KIT	DESCRIZIONE DESCRIPTION	Q.tà Qty.	MODELLI MODELS
65	3609.0058.00		SCREW M8X22	4	
66	0402.0170.00		FLANGE	1	
67	0601.0218.00		SHIM Ø62 0,05 mm	1	
	0601.0220.00		SHIM Ø62 0,10 mm	1	
	0601.0222.00		SHIM Ø62 0,19 mm	1	
	0601.0259.00		SHIM Ø62 0,25 mm	1	
68	0019.0007.00	D	OIL SEAL 25X52X7 mm	1	
69	1210.0388.00	D	O-RING	1	
70	0440.0012.00		ROLLER BEARING	1	
71	1602.0013.00		KEY 8X7X30 mm	1	
72	0001.0324.00		CRANKSHAFT Ø24 mm	1	4030 S
	0001.0325.00		CRANKSHAFT Ø24 mm	1	6020 S
	0001.0345.00		CRANKSHAFT Ø24 mm	1	3530 S
	0001.0346.00		CRANKSHAFT Ø24 mm	1	4525 S - 4530 S 5520 S - 5525 S

E version

POS. ITEM	CODICE PART No.	KIT KIT	DESCRIZIONE DESCRIPTION	Q.tà Qty.	MODELLI MODELS
77	3609.0058.00		SCREW M8X22	4	
78	3016.0017.00		FLANGE	1	
79	3607.0201.00		SCREW 1/2"-13	4	
80	0601.0210.00		SHIM Ø68 0,05 mm	1	
	0601.0212.00		SHIM Ø68 0,10 mm	1	
	0601.0214.00		SHIM Ø68 0,19 mm	1	
	0601.0216.00		SHIM Ø68 0,25 mm	1	
81	0019.0052.00	D	OIL SEAL 40X52X7 mm	1	
82	1210.0109.00	D	O-RING 1,78X 63,22 mm	1	
83	0440.0011.00		ROLLER BEARING 40X68X19	1	
84	0001.0355.00		CRANKSHAFT 1"1/8"	1	3530 E
	0001.0356.00		CRANKSHAFT 1"1/8"	1	4030 E
	0001.0357.00		CRANKSHAFT 1"1/8"	1	4530 E -5530 E

G version solo / only FWS 4030

POS. ITEM	CODICE PART No.	KIT KIT	DESCRIZIONE DESCRIPTION	Q.tà Qty.	MODELLI MODELS
44	3609.0058.00		SCREW M8X22	4	
45	3016.0022.00		FLANGE	1	
46	0601.0270.00		SPACER Ø18X9X4,8 mm	2	
47	3609.0058.00		SCREW M8X22	4	
48	0601.0210.00		SHIM Ø68 0,05 mm	1	
	0601.0212.00		SHIM Ø68 0,10 mm	1	
	0601.0214.00		SHIM Ø68 0,19 mm	1	
	0601.0216.00		SHIM Ø68 0,25 mm	1	
49	0019.0052.00	D	OIL SEAL 40X52X7 mm	1	
50	1210.0109.00	D	O-RING 1,78X 63,22 mm	1	
51	0440.0011.00		ROLLER BEARING 40X68X19	1	
86	0001.0380.00		CRANKSHAFT Ø25 mm	1	

KIT VALVOLA ASP.-MAND. COMPLETE VALVE KIT 5025.0011.00

KIT A

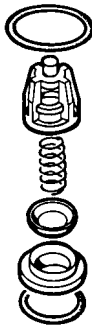

5025.0011.00

POS. ITEM	CODICE PART No.	Q.tà Qty.
4	1210.0046.00	6
5	3009.0087.00	6
6	3604.0017.00	6
7	1802.0177.00	6
8	1205.0025.00	6
9	1210.0048.00	6

KIT GUARNIZIONI PISTONE / PISTON SEAL KIT Ø 18 mm 5019.0038.00 - Ø 20 mm 5019.0039.00

KIT B

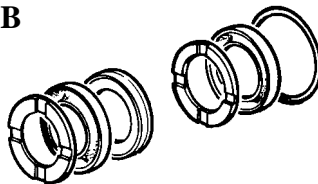

5019.0038.00

POS. ITEM	CODICE PART No.	Q.tà Qty.
11	0009.0199.00	3
12	1241.0026.00	3
13	0009.0100.00	3
15	0009.0199.00	3
16	1241.0026.00	3
18	1210.0156.00	3

5019.0039.00

POS. ITEM	CODICE PART No.	Q.tà Qty.
11	0009.0108.00	3
12	1241.0032.00	3
13	0009.0104.00	3
15	0009.0108.00	3
16	1241.0032.00	3
18	1210.0156.00	3

KIT PISTONE / PISTON KIT

Ø 18 mm 2409.0073.00 - Ø 20 mm 2409.0074.00

KIT C

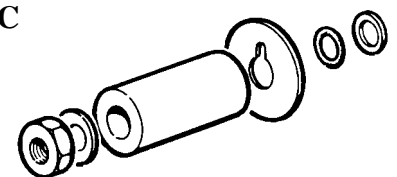

2409.0073.00

POS. ITEM	CODICE PART No.	Q.tà Qty.
20	0600.0054.00	3
21	2811.0082.00	3
22	0202.0022.00	3
23	2812.0042.00	3
24	1210.0039.00	3
25	0009.0170.00	3

2409.0074.00

POS. ITEM	CODICE PART No.	Q.tà Qty.
20	0600.0054.00	3
21	2811.0082.00	3
22	0202.0024.00	3
23	2812.0042.00	3
24	1210.0039.00	3
25	0009.0170.00	3

KIT GUARNIZIONI POMPA / SEAL KIT ALBERO MASCHIO / SOLID SHAFT 5019.0044.00 ALBERO FEMMINA / HOLLOW SHAFT 5019.0045.00

5019.0044.00

POS. ITEM	CODICE PART No.	Q.tà Qty.
4	1210.0046.00	6
9	1210.0048.00	6
18	1210.0156.00	3
19	0019.0066.00	3
24	1210.0039.00	3
25	0009.0170.00	3
34	1210.0333.00	1
35	1210.0216.00	1
39	1210.0441.00	1
68	0019.0007.00	1
69	1210.0388.00	1
74	1210.0388.00	1

5019.0045.00

POS. ITEM	CODICE PART No.	Q.tà Qty.
4	1210.0046.00	6
9	1210.0048.00	6
18	1210.0156.00	3
19	0019.0066.00	3
24	1210.0039.00	3
25	0009.0170.00	3
34	1210.0333.00	1
35	1210.0216.00	1
39	1210.0441.00	1
74	1210.0388.00	1
81	0019.0052.00	1
82	1210.0109.00	1

KIT D

