

Triplex Direct-Drive Plunger Pump

Model 2SF

PUMP FEATURES

- UNIFLOW design provides continuous liquid flow forward through the pump, reduces cavitation risk and increases pump life.
- Triplex design with unique spring loaded inlet valves and the flow through ceramic plungers provides a smooth, steady flow.
- Ultimate portability—less than 11 pounds—less than 10" long.
- Standard shaft pump for direct mounting or special SOLID SHAFT and LOW RPM models.
- Regulating Unloader is standard on each pump to assure system pressure control and pump protection.
- Special Hi-Temp seal option for pumping 190°F water.
- Optional Thermo Valve mounts directly into by-pass hose for optimum heat protection while in by-pass.

COMMON PUMP SPECIFICATIONS

Inlet Pressure Range.....(Standard)	Flooded to 75 PSI	(Flooded to 5.25 BAR)
.....(Hi-Temp)	30 to 75 PSI	(2.1 to 5.25 BAR)
Bore.....	0.708"	(18 mm)
Max. Liquid Temperature...(Standard)	160°F	(71°C)
.....(Hi-Temp)	190°F	(88°C)
Crankcase Capacity.....	11.83 oz.	(.35 L)
Inlet Ports (1).....	3/8" NPTF	(3/8" NPTF)
Discharge Ports (2).....	3/8" NPTF	(3/8" NPTF)
By-Pass Ports (1).....	1/4" NPTF	(1/4" NPTF)
Weight (Pump Only).....	10.6 lbs.	(4.8 kg)
Dimensions (Pump Only).....	9.13 x 6.65 x 6.50"	(232 x 169 x 165mm)

⚠ WARNING

All systems require both a primary pressure regulating device (i.e., regulator, unloader) and a secondary pressure safety relief device (i.e., pop-off valve, safety valve). Failure to install such relief devices could result in personal injury or damage to the pump or to system components. CAT PUMPS does not assume any liability or responsibility for the operation of a customer's high pressure system.

SPECIFICATIONS

	U.S. Measure	Metric Measure	U.S. Measure	Metric Measure
MODEL	2SF05ELS		2SF10ES	
Flow	0.5 GPM	(1.9 L/M)	1.0 GPM	(3.8 L/M)
Max. Discharge Pressure.....	2000 PSI	(140 BAR)	2000 PSI	(140 BAR)
Max. RPM.....	1725 RPM	(1725 RPM)	3450 RPM	(3450 RPM)
Stroke	0.067"	(1.7 mm)	0.067"	(1.7 mm)
MODEL	2SF20ES		2SF22ES	
Flow	2.0 GPM	(7.6 L/M)	2.2 GPM	(8.3 L/M)
Max. Discharge Pressure.....	2000 PSI	(140 BAR)	2000 PSI	(140 BAR)
Max. RPM.....	3450 RPM	(3450 RPM)	3450 RPM	(3450 RPM)
Stroke	0.122"	(3.1 mm)	0.132"	(3.35 mm)
MODEL	2SF22ELS		2SF22SLS	
Flow	2.2 GPM	(8.3 L/M)	2.2 GPM	(8.3 L/M)
Max. Discharge Pressure.....	2000 PSI	(140 BAR)	2000 PSI	(140 BAR)
Max. RPM.....	1725 RPM	(1725 RPM)	1725 RPM	(1725 RPM)
Stroke	0.248"	(6.3 mm)	0.248"	(6.3 mm)
MODEL	2SF29ELS		2SF30ES	
Flow	2.85 GPM	(10.8 L/M)	3.0 GPM	(11.4 L/M)
Max. Discharge Pressure.....	1500 PSI	(105 BAR)	1500 PSI	(105 BAR)
Max. RPM.....	1725 RPM	(1725 RPM)	3450 RPM	(3450 RPM)
Stroke	0.335"	(8.5 mm)	0.177"	(4.5 mm)
MODEL			2SF30GS	
Flow			3.0 GPM	(11.4 L/M)
Max. Discharge Pressure.....			2000 PSI	(140 BAR)
Max. RPM.....			3450 RPM	(3450 RPM)
Stroke			0.189"	(4.8 mm)
MODEL	2SF35ES		2SF35GS	
Flow	3.5 GPM	(13.2 L/M)	3.5 GPM	(13.2 L/M)
Max. Discharge Pressure.....	1500 PSI	(105 BAR)	2000 PSI	(140 BAR)
Max. RPM.....	3450 RPM	(3450 RPM)	3450 RPM	(3450 RPM)
Stroke	0.220"	(5.6 mm)	0.220"	(5.6 mm)

Optional Electric-3/4" Shaft - 2SF30GES, 2SF35GES

ES, ELS = **Electric 5/8"** hollow shaft with bolt mount
 GES = **Electric 3/4"** hollow shaft with bolt mount
 GS = **Gas 3/4"** hollow shaft with bolt and adapter mount
 SLS = **Electric 3/4"** solid shaft complete with bracket mount.
 Add "3" to PN for Hi-Temp version.

Refer to pump Service Manual for repair procedures and additional technical information.

"Customer confidence is our greatest asset"

EXPLODED VIEW

November 2003

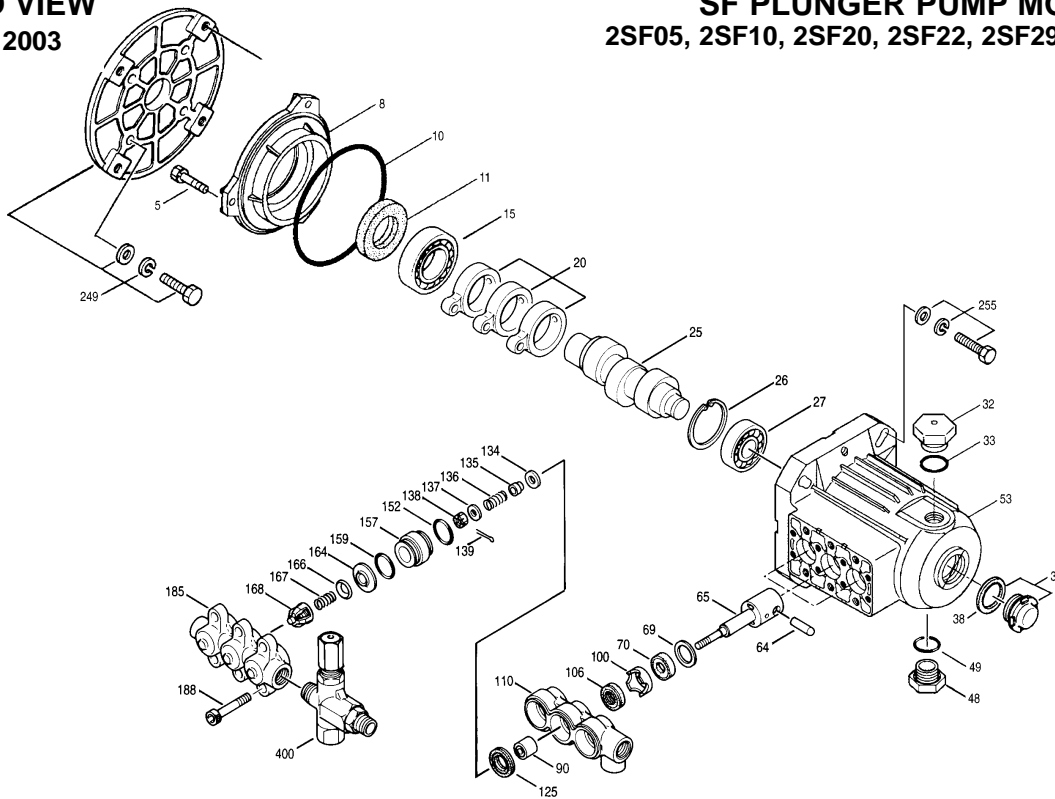

SF PLUNGER PUMP MODELS

2SF05, 2SF10, 2SF20, 2SF22, 2SF29, 2SF30, 2SF35

PARTS LIST

ITEM	P/N	MATL	DESCRIPTION	MODEL USED	QTY	ITEM	P/N	MATL	DESCRIPTION	MODEL USED	QTY
5	547161	STCP	Screw, HH (M6 x 14) [3/03]	All Models	3	135	44871	S	Spacer, Inlet	All Models	3
8	547153	AL	Cover, Bearing, Inner [3/03]	All Models	1	136	44872	S	Spring, Inlet Valve	All Models	3
10	14041	NBR	O-Ring, Bearing Cover [3/03]	All Models	1	137	88575	S	Washer, Conical (M6)	All Models	3
11	55337	NBR	Seal, Oil [3/03]	All Models	1	138	27000	S	Nut, Slotted (M6)	All Models	3
15	14488	STL	Bearing, Ball, Inner	All Models	1	139	14158	S	Cotterpin (M1.6x10)	All Models	3
20	547046	TNM	Rod, Connecting	All Models	3	152	26089	NBR	O-Ring, Adapter, Inner - 80D	All Models	3
25	543135	FCM	Crankshaft, 1725/3450 RPM, 5/8", 1.7mm	05ELS, 10ES	1	11377	FPM	O-Ring, Adapter, Inner - 80D	All Models	3	
	46109	FCM	Crankshaft, 3450 RPM, 5/8", 3.1mm	20ES	1	157	44878	BB	Discharge Valve Adapter	All Models except 29ELS	3
	44933	FCM	Crankshaft, 3450 RPM, 3/4", 3.35mm	22GS	1	45430	BB	Discharge Valve Adapter	29ELS	3	
	44929	FCM	Crankshaft, 3450 RPM, 5/8", 3.35mm	22ES	1	159	26089	NBR	O-Ring, Adapter, Outer - 80D	All Models	3
	546334	FCM	Crankshaft, 3450 RPM, 3/4", 4.8mm	30GS	1	11377	FPM	O-Ring, Adapter, Inner - 80D	All Models	3	
	44931	FCM	Crankshaft, 3450 RPM, 5/8", 4.5mm	30ES	1	164	44881	S	Seat	All Models	3
	45096	FCM	Crankshaft, 3450 RPM, 5/8", 5.6mm	35ES	1	166	43723	S	Valve	All Models	3
	46017	FCM	Crankshaft, 3450 RPM, 3/4", 5.6mm	35GS	1	167	541062	S	Spring	All Models	3
	45160	FCM	Crankshaft, 1725 RPM, 5/8", 6.3mm	22ELS	1	168	44565	PVDF	Retainer, Spring	All Models	3
	45426	FCM	Crankshaft, 1725 RPM, 5/8", 8.5mm	29ELS	1	185	44879	BB	Manifold, Discharge	All Models	1
	45146	FCM	Crankshaft, 1725 RPM, Solid, 3/4", 6.3mm	22SLS	1	188	87859	STZP	Screw, HSH (M8x75)	All Models	6
26	12385	STL	Ring, Retaining	All Models	1	249	30968		Assy, Adapter Mount, Gas	30G, 35G	1
27	15710	STL	Bearing, Ball, Outer	All Models	1		15845	STZP	Lockwasher, Split (M8)		4
32	45690	RTP	Cap, Oil Filler	All Models	1		44843	STZP	Screw, HH (5/16-24)		4
33	14179	NBR	O-Ring, Oil Filler Cap - 70D	All Models	1		547035	AL	Flange		1
37	92241		Gauge, Bubble Oil w/Gasket - 80D	All Models	1		12489	STZP	Washer, Flat (M8)		4
38	44428	NBR	Gasket, Flat Flex., Oil Gauge - 80D	All Models	1	255	30517	STZP	Assy, Bolt Mount	All Models	1
48	44842	NY	Plug, Drain (1/2" NPT)	All Models	1		30980	STZP	Washer, Flat (3/8")		4
49	14179	NBR	O-Ring, Drain Plug - 70D	All Models	1		30921	STZP	Lockwasher, Split (3/8")		4
53	547285	AL	Crankcase [3/03]	All Models	1		34100	STZP	Screw, HH (3/8"-16 x 1-3/8")		4
64	16948	CM	Pin, Crosshead	All Models	3		6106		Lubricant, Antiseize		1
65	44865	SZZ	Rod, Plunger	All Models except 29ELS	3		30050	STL	Key (3/16" x 3/16" x 1-1/4" HD)		1
	45427	SZZ	Rod, Plunger	29ELS	3	259	30973	STZP	Kit, Mounting Bracket (Incl. w/Pump)	22SL	1
69	20017	STZP	Washer (M24)	All Models	3				(Inclds: Bracket, Washers, Bolts, Nuts)		
70	25461	NBR	Seal, Oil	All Models	3	285	80228	STL	Screw (M8-1.25x80) (Not Shown)	All Models	2
90	45847	CC	Plunger (M18x14)	All Models except 29ELS	3	300	34053	NBR	Kit, Seal (Inclds: 106,125,139,152, 159)	All Models	1
	45429	CC	Plunger (M18x16)	29ELS	3		33953	HT	Kit, Seal - Hi-Temp (Inclds: 106,125,134,139,152,159)	All Models	1
100	44869	PVDF	Retainer, Seal	All Models	3		33453	FPM	Kit, Seal (Inclds: 106,125,139,152, 159)	All Models	1
106	44876	NBR	Seal, LPS w/S-Spg	All Models	3	310	34052	NBR	Kit, Valve (Inclds: 152,159,164,166,167,168)	All Models	1
	545192	FPM	Seal, LPS w/SS-Spg	All Models	3	311	34668	NBR	Kit, Inlet Valve (Inclds: 134-137,139,152,159)	All Models	1
110	44874	BB	Manifold, Inlet	All Models	1	352	44050	STZP	Tool, Oil Gauge Removal	All Models	1
125	43245	SNG	Seal, HPS w/S	All Models	3	400	75005	BB	Unloader, Regulating	All Models	1
	46652	HT	Seal, Hi-Temp (190° Max)	All Models	3		36086		Assembly, Pulsator	All Models	1
134	45854	S	Valve, Inlet	All Models	3		6565.8		Service Video, Section 8	All Models	1
	33873	NY	Valve, Inlet, Hi-Temp	All Models	3		6107		Oil, Bottle (21 oz) ISO 68 Multi-Viscosity Hydraulic (Fill to specified crankcase capacity prior to start-up)	All Models	1

Bold print part numbers are unique to a particular pump model. Italics are optional items. [] Date of latest production change.

See Tech Bulletins 002, 024, 036, 043, 055, 060, 064, 065, 070, 073, 074, 083 and 092 for additional information.

NOTE: Discard Key which may come standard with most motors and engines and **use only the key included in this kit.**

MATERIAL CODES (Not Part of Part Number): AL=Aluminum BB=Brass CC=Ceramic CM=Chrome-Moly FCM=Forged Chrome-moly FPM=Fluorocarbon (Viton®)

HT=Hi-Temp (EPDM Alternative) NBR=Medium Nitrile (Buna-N) NY=Nylon PVDF=Fluoroplastic (High Strength) RTP=Reinforced Composite

S=304SS SNG=Special Blend (Buna) STL=Steel STCP=Steel/Chrome Plated STZP=Steel/Zinc Plated SZZ=304SS/Zamak TNM=Special High Strength

Center raised pilot guide on the **Adapter Plate** assures proper alignment of pump and engine. Before mounting pump onto engine inspect engine for **recessed seal and bearing guide** to permit adapter to completely seat into recess and four bosses to be flush with engine face.

UNLOADER SPECIFICATIONS

MODEL 7500S	U.S. Measure	Metric Measure
GPM	0.5-6.0 GPM	(2-23 L/M)
PSI	100-2000 PSI	(7-140 BAR)
Inlet Port - Rear	3/8" NPTM	(3/8" NPTM)
Discharge Port - Front	M18 x 1.0	(M18 x 1.0)
By-pass Port - Bottom	3/8" NPTF	(3/8" NPTF)
Weight	14 oz.	(0.43 kg)
Dimensions	3.0 x 1.0 x 4.25"	(76 x 25 x 108 mm)

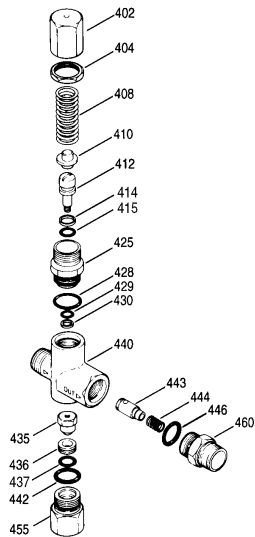

ITEM	P/N	MATL	DESCRIPTION	QTY.
402	540081	BB	Cap, Hex Adjusting	1
404	31047	BB	Nut (M18 x 1)	1
408	32094	STZP	Spring, Coil	1
410	107672	BB	Retainer, Spring	1
412	45694	S	Stem, Piston (M5)	1
414	20184	PTFE	Back-up-Ring, Piston Stem	1
415	14190	NBR	O-Ring, Piston Stem - 70D	1
	14161	FPM	O-Ring, Piston Stem	1
425	107673	BB	Retainer, Piston	1
428	13969	NBR	O-Ring, Piston Retainer - 70D	1
	14320	FPM	O-Ring, Piston Retainer	1
429	14759	NBR	O-Ring, Body	1
	14160	FPM	O-Ring, Body	1
430	107675	PTFE	Back-up-Ring, Body	1
435	45696	BB	Valve and Ball Assembly (M5)	1
436	107680	S	Seat	1
437	13963	NBR	O-Ring, Seat	1
	14303	FPM	O-Ring, Seat	1
440	—	BB	Body	1
442	13969	NBR	O-Ring, By-Pass Fitting - 70D	1
	14320	FPM	O-Ring, By-Pass Fitting	1
443	541060	BB	Valve, Check w/O-Ring	1
444	45924	S	Spring - 85G	1
446	13969	NBR	O-Ring, Discharge Fitting - 70D	1
	14320	FPM	O-Ring, Discharge Fitting	1
455	45695	BB	Fitting, By-Pass (3/8" NPTF)	1
460	107681	BB	Fitting, Discharge (3/8" NPTM)	1
465	7090	BB	By-Pass Hose (15" x 3/8") 160°F	1
466	7090.40	BB	By-Pass Hose w/Thermo Valve	1
468	32097	NBR	Kit, O-Ring (Incls: 414,415,428,429,430,437,442,446)	1
	31627	FPM	Kit, O-Ring (Incls: 414,415,428,429,430,437,442,446)	1
485	7140	BB	Valve, Thermo	1
486	34600	BB	Tee, T.V. Mount	1
487	—	BB	Nipple, T.V. Mount	1

Italics are optional items.

MATERIAL CODES (Not Part of Part Number): BB=Brass NBR=Medium Nitrile (Buna-N)
PTFE=Pure Teflon® S=304SS STZP=Steel/Zinc Plated

OPERATION

A Regulating Unloader comes with each 2SF pump to provide system pressure regulation and pump protection. For suction feed consult CATPUMPS.

By-pass for the regulating unloader may drain to the ground, drain to a reservoir or connect to the special 1/4" by-pass port on the underside of the inlet manifold. A 3/8" flexible hose and Thermo Valve (7090.40) are recommended. **DO NOT EXCEED 6 MINUTES in BY-PASS when Thermo Valve is not installed.**

Hi-Temp Units with special Hi-Temp seals do not the Thermo Valve. Use optional Dual Pressure Switches and Mechanical Relay in Auto Shut Off Kits 34870 and 34871.

If unit is INFREQUENTLY USED OR PERIODICALLY STORED, seals may become dry. System should be PURGED BEFORE OPERATION (system liquid must flow through the pump without discharge restriction) to assure full system pressure is reached.

CHEMICAL INJECTOR SPECIFICATIONS

MODEL	Standard	Optional
Flow	7193 3-4 GPM	7194 4-5 GPM
Nozzle Orifice	2.1mm	2.3mm
Hose Barb	1/4"	1/4"
Inlet Port	M18 x 1.0	M18 x 1.0
Discharge Port	3/8" NPTM	3/8" NPTM
Weight	6.3 oz.	6.3 oz.
Dimensions	2 x 1 x 3"	2 x 1 x 3"

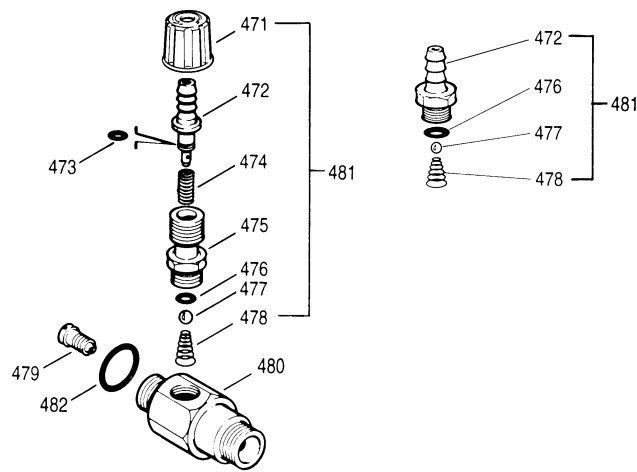

ITEM	P/N	MATL	DESCRIPTION	QTY.
471	33949	NY	Handle, Adjustment	1
472	32941	BB	Barb, Adjustable	1
	33505	BB	Barb, Fixed	1
473	—	NBR	O-Ring, Hose Barb	1
474	33500	S	Spring	1
475	33946	BB	Retainer, Ball Seat	1
476	33504	FPM	O-Ring, Retainer	1
477	34620	SS	Ball	1
478	33501	SS	Spring, Tapered	1
479	32373	S	Orifice, Injector (2.1mm) Standard	1
	32374	S	Orifice, Injector (2.3mm)	1
480	—	BB	Body	1
481	33481	BBNY	Barb, Assy, Adjustable (Incls: 471, 472, 473, 474, 475, 476, 477, 478)	1
—	33480	BB	Barb, Assy, Fixed (Incls: 472, 476, 477, 478)	1
482	13969	NBR	O-Ring, Body - 70D	1

Italics are optional items.

MATERIAL CODES (Not Part of Part Number): BB=Brass FPM=Fluorocarbon (Viton®)
NBR=Medium Nitrile (Buna-N) NY=Nylon S=304SS SS=316SS

CHEMICAL INJECTOR PERFORMANCE CHART

Optional Special Ported Chemical Injector for Unloader Mounting

Standard Pump Model	Injector Orifice Size	Lo-Pressure Nozzle Rating (Maximum Downstream) (Press for Injector)	Max. Chem. Draw (0 PSI) (Downstream)	Hi-Press Nozzle "Deduction" (Press. drop across Inj.)
2SF20	2.1 mm (7193)	100 PSI	50 oz/min	100 PSI
2SF22	2.1 mm (7193)	75 PSI	50 oz/min	100 PSI
2SF29, 2SF30	2.1 mm (7193)	225 PSI	50 oz/min	150 PSI
2SF35	2.3 mm (7194)	150 PSI	50 oz/min	150 PSI

Optimum performance of chemical injector occurs with a 35 ft. high pressure hose and a minimum 3/8" I.D. The type of hose, extended lengths, reduced I.D. and fittings may create back pressures in excess of the low pressure nozzle rating and prevent the injector from drawing chemical. Deduct hose friction loss from above low PSI Nozzle. Contact CAT PUMPS for assistance with other options. Refer to Hose Friction Loss Chart in the Service Manual for pressure loss with longer hose.

An optional, **specially ported chemical injector** may be mounted directly to the discharge of the unloader. Remove o-ring, check valve and spring from discharge fitting of unloader; insert into injector and thread into unloader discharge port. **Discard o-ring and discharge fitting.** Refer to the performance chart to determine the orifice size best suited to the system flow. **Chemical draw occurs under low pressure.** Select the Change Over Nozzle (32149), Adjustable Nozzle (32151), or Vari-Nozzle (7930-7980) to permit the adjustment from low to high pressure.

For optimum performance when using a chemical injector, use a **single wire braid hose** on the discharge line. Too flexible a hose will prevent the unloader from receiving the full pressure signal to activate the by-pass mode.

For correct nozzle selection, **read system pressure at the pump. DO NOT READ SYSTEM PRESSURE AT THE HIGH PRESSURE GUN.** Incorrect pressure reading may result in: pump operation at excessive pressures, inconsistent chemical draw, or possible damage to the pump or unloader.

MOTOR SPECIFICATIONS

Model 8050

Horsepower	1.5
Shaft Diameter.....	5/8"
Max. Volts.....	115/230
FULL LOAD AMPS.....	12.1
RPM.....	3450
Weight.....	32.1 lbs.
Phase.....	Single
Frame Size.....	56-C TEFC
Service Factor.....	1.15

Model 8052

Horsepower	2.0
Shaft Diameter.....	5/8"
Max. Volts.....	115/230
FULL LOAD AMPS.....	17.0/9.2-8.5
RPM.....	3450
Weight.....	32.5 lbs.
Phase.....	Single
Frame Size.....	56-C TEFC
Hertz.....	60
Service Factor.....	1.15

Model 8055

Horsepower	3.0
Shaft Diameter.....	●3/4"
Max. Volts.....	208/230
FULL LOAD AMPS.....	15.2/13.6
RPM.....	3450
Weight.....	46.3 lbs.
Phase.....	Single
Frame Size.....	56-C TEFC
Service Factor.....	1.15

● Use 3/4" shaft size motor with GES Pumps.

Model 8057

Horsepower	5.0
Shaft Diameter.....	●3/4"
Max. Volts.....	230
FULL LOAD AMPS.....	22.0
RPM.....	3450
Weight.....	40 lbs.
Phase.....	Single
Frame Size.....	56-C OPEN DRIP
Service Factor.....	1.15

● Use 3/4" shaft size motor with GES Pumps.

*** Model 8060**

Horsepower	1.5
Shaft Diameter.....	5/8"
Max. Volts.....	115/230
FULL LOAD AMPS.....	14.0/7.0
RPM.....	1725
Weight.....	40 lbs.
Phase.....	Single
Frame Size.....	56-C TEFC
Service Factor.....	1.2

* Use with ELS models or to reduce flow by 50% on standard models.

*** Model 8062**

Horsepower	2.0
Shaft Diameter.....	5/8"
Max. Volts.....	115/230
FULL LOAD AMPS.....	17.0/8.5
RPM.....	1725
Weight.....	43.7 lbs.
Phase.....	Single
Frame Size.....	56-C TEFC
Service Factor.....	1.15

* Use with ELS models or to reduce flow by 50% on standard models.

Common Motor Specifications

Max. Ambient Temp.....	104°F
Capacitor Start	Yes
Thermal Overload-Manual Reset	Yes
U.L. Construction Reference	
(8050,8055).....	E49747
(8052, 8057, 8060, 8062)	E44549
U.L. Insulation Reference (All) ...	E37878
CSA Reference	
(8050)	LR45148
(8052, 8057, 8060, 8062).....	LR4642
(8055).....	LR2025

Note: Motor Start-Up AMPS may vary, then settle within FULL LOAD AMPS rating after initial run in time.

★ ★ Before mounting pump on motor, apply P.N. 6106 Antiseize Lubricant to pump shaft.

★ ★ Refer to Tech Bulletin 055 for instructions on removing pump from gas engine or electric motor.

Add .050 for 50 Hz (1450 or 2850 RPM)

For warranty consideration contact CAT PUMPS for the local **Authorized Service Center**. If you are uncertain as to the cause of failure (Pump or Motor), secure **Returned Goods Authorization number** and return complete assembly **PREPAID** to CAT PUMPS for evaluation.

HORSEPOWER REQUIREMENTS							
FLOW		PRESSURE					PUMP RPM
		PSI 700	PSI 1000	PSI 1200	PSI 1500	PSI 2000	
U.S. GPM	Metric L/M	BAR 50	BAR 70	BAR 85	BAR 105	BAR 140	
0.5	1.9	.24	.34	.41	.50	.68	1725
1.0	3.8	.48	.69	.82	1.0	1.4	3450
2.2	8.3	1.1	1.5	1.8	2.3	3.0	3450
2.85	10.8	1.36	2.0	2.3	2.9	N/A	1725
3.0	11.4	1.4	2.1	2.5	3.1	4.1	3450
3.5	13.2	1.7	2.4	2.9	3.6	N/A	3450

DETERMINING THE REQUIRED H.P.		
$\frac{\text{GPM} \times \text{PSI}}{1460}$	=	Electric Brake H.P. Required

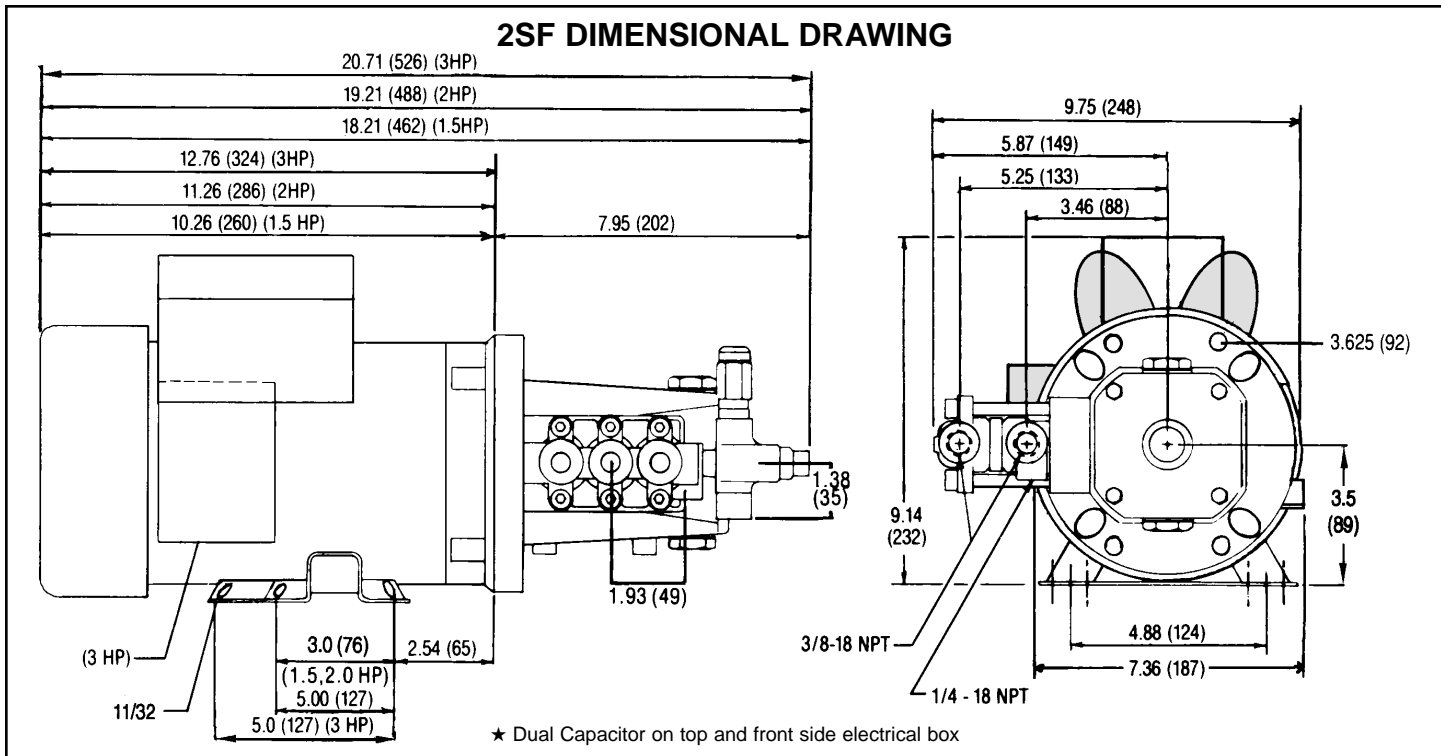

Products described hereon are covered by one or more of the following U.S. patents 3558244, 3652188, 3809508, 3920356, 3930756 and 5035580

World Headquarters
CAT PUMPS
 1681 - 94th Lane N.E. Minneapolis, MN 55449-4324
 Phone (763) 780-5440 — FAX (763) 780-2958
 e-mail: techsupport@catpumps.com
 www.catpumps.com



CAT PUMPS (U.K.) LTD.
 1 Fleet Business Park, Sandy Lane, Church Crookham, Fleet Hampshire GU52 8BF, England
 Phone Fleet 44 1252-622031 — Fax 44 1252-626655
 e-mail: sales@catpumps.co.uk

N.V. CAT PUMPS INTERNATIONAL S.A.
 Heiveldekens 6A, 2550 Kontich, Belgium
 Phone 32-3-450.71.50 — Fax 32-3-450.71.51
 e-mail: cpi@catpumps.be www.catpumps.be

CAT PUMPS DEUTSCHLAND GmbH
 Buchwiese 2, D-65510 Idstein, Germany
 Phone 49 6126-9303 0 — Fax 49 6126-9303 33
 e-mail: catpumps@t-online.de www.catpumps.de

International Inquiries
 FAX (763) 785-4329
 e-mail: intlsales@catpumps.com