

10918

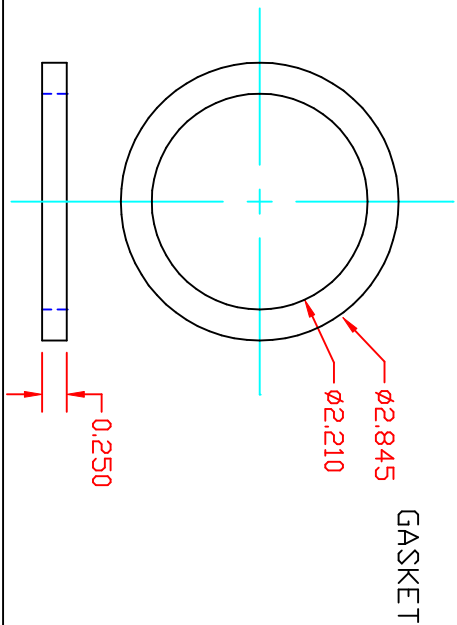

BODY

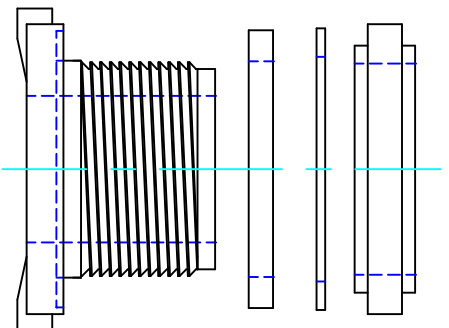
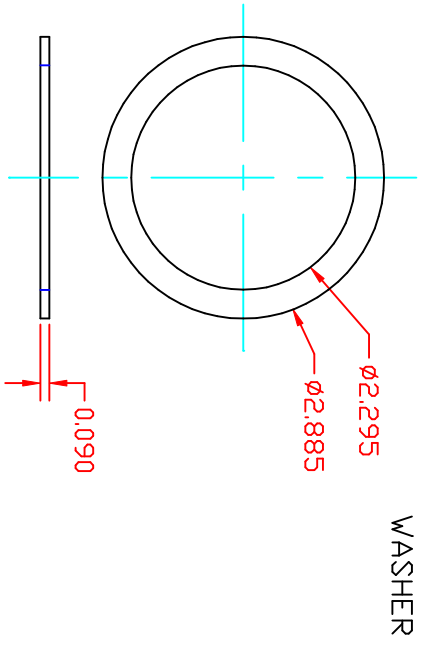
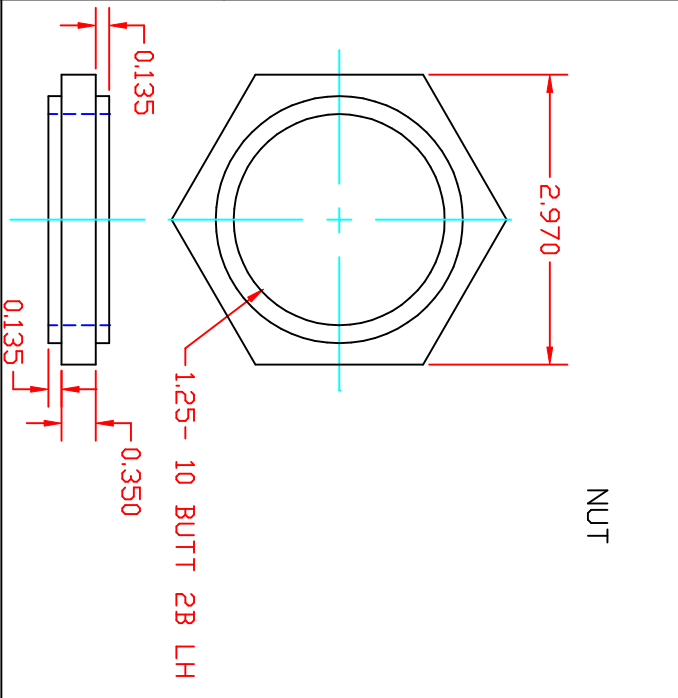
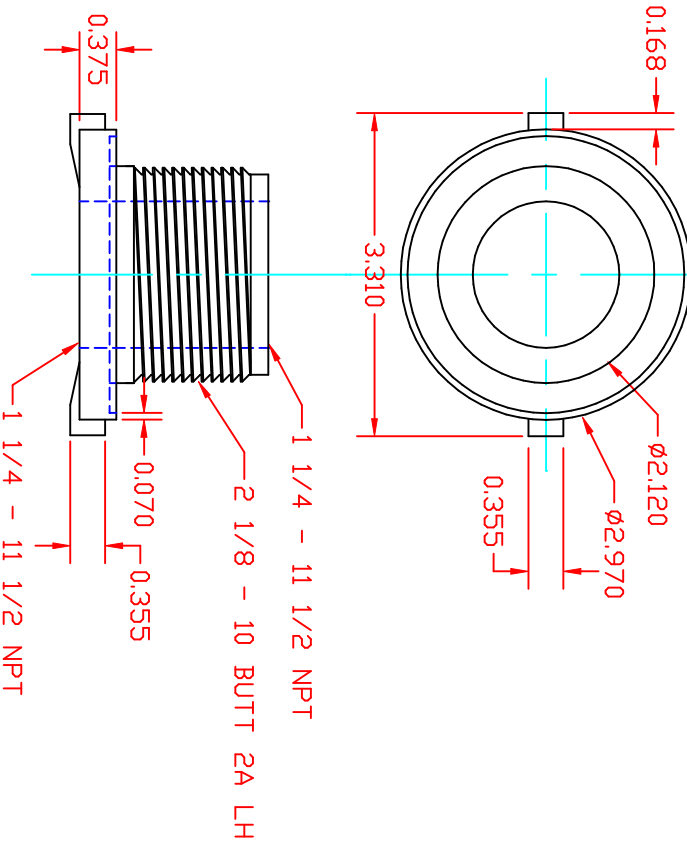

DRAWN / DATE DHJ/1/27/03		MATERIAL / SHOT WEIGHT	
APPRD. / DATE		NOTES:	
REV	DESCRIPTION	DATE APPRD.	THIRD ANGLE PROJECTION ANSI 14.5M
ALL DIMENSIONS ARE IN DECIMAL INCHES TOLERANCES UNLESS OTHERWISE SPECIFIED			
ACE 1 1/4 BULKHEAD FITTING		ACE 1 1/4 BULKHEAD FITTING	
SCALE NONE		PART NO. 10918	
CLIENT / DESCRIPTION A DIVISION OF DEN HARTOG INDUSTRIES, INC.		CLIENT / DESCRIPTION A DIVISION OF DEN HARTOG INDUSTRIES, INC.	